

Fronius IG Plus

35 / 50 / 70 / 100 / 120 / 150

USA Operating Instructions

Inverter for grid-connected photo-voltaic systems



Dear Fronius Customer,

Introduction

Thank you for choosing Fronius - and congratulations on your new, high-quality, high-tech Fronius product. This introduction should provide you with general information about the equipment. Please read it carefully to learn about the many great features of your new Fronius product. This is the best way to get the most out of all the advantages that it has to offer.

Please also note the safety information and the safety precautions for the product installation location. Following all product instructions will ensure long-lasting quality and reliability. And these are the essential ingredients for outstanding results.



Safety Instructions

DANGER!



„**DANGER!**“ indicates an imminently hazardous situation which, if not avoided, will result in death or serious injury.

WARNING!



„**WARNING!**“ indicates a potentially hazardous situation which, if not avoided, will result in death or serious injury.

CAUTION!



„**CAUTION!**“ indicates a potentially harmful situation which, if not avoided, may result in minor and moderate injury or property damage.

NOTE



„**NOTE**“ indicates a situation which could adversely affect work results and may cause damage to equipment.

Important

„**Important**“ indicates practical tips and other useful information. It is not a signal word for a harmful or dangerous situation.

Please pay special attention when one of the above symbols appears in the manual.

General



This equipment has been manufactured using state-of-the-art technology and in accordance with general safety regulations. However, incorrect operation or misuse may endanger

- the life and well-being of the operator or third parties
- the equipment and other property of the owner/operator
- the efficient operation of the equipment

All persons involved with equipment startup, service and maintenance must

- be suitably qualified
- be familiar with electrical installations
- have completely read and followed these operating instructions

The operating instructions must be available at the equipment location at all times. In addition to the operating instructions, all applicable local rules and regulations regarding accident prevention and environmental protection must also be followed.

General (continued)

All safety instructions and warning signs on the equipment itself:

- must be maintained in legible condition
- must not be damaged
- must not be removed
- must not be covered or painted over

For information about where the safety instructions and warning signs are located on the equipment, please refer to the „General“ section of your equipment’s operating instructions.

Any equipment malfunctions which might impair safety must be remedied immediately before the device is turned on.

Your safety is at stake.

Intended Use



The equipment may only be operated in compliance with its intended use.

Any other purpose does not constitute intended use. The manufacturer is not responsible for any damages resulting from unintended use.

Intended use also includes

- reading and compliance with all general information as well as safety information and warnings from the operating instructions
- compliance with all inspection and maintenance requirements
- installation as per operating instructions

Where appropriate, the following guidelines should also be applied:

- Utility company regulations regarding mains feed-in
- Information from solar module manufacturer

Ambient Conditions



Operation and/or storage of the device outside of the stipulated range does not constitute intended use. The manufacturer is not responsible for any damages resulting from unintended use.

Please refer to the technical data in your operating instructions for information about permitted ambient conditions.

Qualified Personnel



The service information in these operating instructions is only intended for qualified personnel. An electrical shock can be fatal. Please do not carry out any activities other than those referred to in the documentation even if you are suitably qualified.



All cables and wires must be secured, undamaged, insulated and adequately dimensioned. Loose connections, scorched, damaged or under-dimensioned cables and wires must be repaired immediately by an authorized specialist.

Qualified Personnel
(continued)



Maintenance and repair may only be carried out by an authorized specialist.

The use of third-party parts does not guarantee that they were designed and manufactured according to operational demands and safety requirements. Use only original spare parts (also applies to standard parts).

Do not carry out any alterations, installations or modifications to the device without first obtaining the manufacturer's permission.

Immediately replace any components that are not in perfect condition.

Safety Precautions at Equipment Location

When installing devices with air vents, make sure that cool air can flow freely through the vents unobstructed. The device should only be operated in accordance with the protection class listed on the rating plate.

EMC Precautions



Care must be taken during installation to ensure that there is no electromagnetic interference with electrical and electronic equipment.

Electrical Installations



Electrical installations may only be carried out in accordance with relevant national and local standards and regulations.

ESD Precautions



Danger of damage to electronic components due to electrostatic discharge. Take appropriate ESD precautions when replacing and installing components.

Safety Precautions in Normal-Operation



The device should only be operated when all safety equipment is fully functional. If safety equipment is not fully functional, there is a danger to

- the life and well-being of the operator or third parties
- the equipment and other property of the owner/operator
- the efficient operation of the equipment

Safety equipment that is not fully functional must be repaired by an authorized specialist before the device is turned on.

Never bypass or disable safety equipment.



Safety Markings



Equipment with the CE marking fulfils the basic requirements of the Guideline Governing Low-Voltage and Electromagnetic Compatibility. (For more information, please see the attachment and/or the „Technical Data“ section in your documentation).

Disposal



This device should not be disposed of in residential waste. To comply with European Directive 2002/96/EC on Waste Electrical and Electronic Equipment and its implementation as national law, electrical equipment that has reached the end of its life must be collected separately and returned to an approved recycling facility. Any device that you no longer require must be returned to your dealer or you must find an approved collection and recycling facility in your area. Ignoring this EU Directive may have adverse affects on the environment and your health.

Data Security

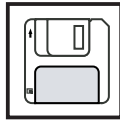

The user is responsible for backing up data relating to changes made to factory settings. The manufacturer will not accept liability if personal settings are deleted.

Copyright



The manufacturer maintains the copyright to these operating instructions.

Text and illustrations are technically correct at the time of going to print. The right to make modifications is reserved. The contents of the operating instructions shall not provide the basis for any claims whatsoever on the part of the purchaser. We would be grateful for any comments or suggestions regarding improvements and/or error corrections for the operating instructions.

Table of Contents

Operation	7
Operator and Equipment Protection	9
Safety	9
Operator and Equipment Protection	9
Galvanic Isolation	9
Monitoring the mains network	9
The Fronius IG Plus in the Photovoltaic System	10
General	10
Tasks	10
Converting DC to AC current	10
Fully Automatic Operational Management	10
Display Function and Data Communication	10
System Upgrades	11
Inverter Cooling using Forced-air Ventilation	11
Power Derating	11
Fronius IG Plus Device Description	12
Controls and Indicators	12
Display	12
Startup Phase	14
Test Procedure	14
LED Operating Status	16
Navigating Around the Display	18
Activating Display Illumination	18
Accessing Menus	18
Selecting a display mode	19
Scrolling Between Display Values	19
Overview of Display Values	20
Display Modes	21
Display Modes	21
Overview	21
Display Values in 'Now' Display Mode	22
Selecting 'Now' Display Mode	22
Display Values in 'Now' Display Mode	22
Options	24
Display Values in 'Day / Year / Total' Display Mode	25
General	25
Selecting 'Day / Year / Total' Display Mode	25
Display Values in 'Day / Year / Total' Display Mode	26
Options	28
The Setup Menu	29
Default Settings	29
Opening the setup menu	29
Scrolling through Menu Options	30
Menu Options in the Setup Menu	30

Setting and Displaying Menu Options	33
General Menu Option Settings	33
Setting the 'Standby' Menu Option	33
Setting the 'CONTRast' menu option	34
Setting the 'LIGHTmode' menu option	34
Setting the 'CASH' Menu Option	35
Setting the 'IG No.' Menu Option	37
Setting the 'DATcom' Menu Option	38
Setting the 'TIME' Menu Option	40
Displaying the 'STATEps' menu option	43
Displaying the 'VERSlon' menu option	44

Installation and Startup 47

Fronius IG Plus Installation and Connection	49
Fronius IG Plus Setup	49
Overview	49
Fronius IG Plus Connection Options	50
Fronius IG Plus Connection Options	50
Target Punch-outs on the Fronius IG Plus	52
General	52
Target Punch-outs for Cable Inputs	52
Location Selection	54
General Location Selection	54
Location Selection for Inside Installation	54
Location Selection for Outside Installation	55
Fronius IG Plus Installation	56
Attaching Wall Bracket	56
Fronius IG Plus Installation	57
Connecting the Fronius IG Plus to the Public Grid (AC)	58
Monitoring the Mains Network	58
Installations with Several Inverters	58
AC-side Terminals	58
Cross Section of AC Cable	59
Connecting the Fronius IG Plus to the Public Grid (AC)	59
Fuse Recommendation for the AC-side	60
Connecting Solar Module Strings to the Fronius IG Plus (DC)	61
General Information About Solar Modules	61
Safety	61
DC-Terminals	62
Overview	62
Ungrounded System: Connecting Solar Module Strings	63
Cable Cross Section of Solar Module Strings	63
Ungrounded System: Connecting Solar Module Strings	63
Selecting String Fuses	65
Using String Fuses in Fronius IG Plus	65
Criteria for the Proper Selection of String Fuses	66
General	66
Criteria for the Proper Selection of String Fuses	66
Effects of using underrated fuses	66
Fuse Recommendations - Application Example	66
Fuses	67

Ungrounded System: Connecting Solar Module Strings with a Cable Cross Section > 16 mm ²	68
General	68
Additional Required Components	68
Ungrounded System: Connecting Solar Module Strings with a Cable Cross Section > 16 mm ²	68
Solar Module Ground at Negative Pole: Connecting Solar Module Strings	71
General	71
Cable Cross Section of Solar Module Strings	71
Solar Module Ground at Negative Pole: Connecting Solar Module Strings	71
Selecting String Fuses	73
Using String Fuses in Fronius IG Plus	73
Criteria for the Proper Selection of String Fuses	74
General	74
Criteria for the Proper Selection of String Fuses	74
Effects of using underrated fuses	74
Fuse Recommendations - Application Example	74
Fuses	75
Solar Module Ground at Negative Pole: Connecting Solar Module Strings with a Cable Cross Section > 16 mm ²	76
General	76
Additional Required Components	76
Solar Module Ground at Negative Pole: Connecting Solar Module Strings with a Cable Cross Section > 16 mm ²	77
Solar Module Ground at Negative Pole: Connecting Solar Module Strings with a Cable Cross Section > 16 mm ²	78
Solar Module Ground at Negative Pole for Fronius IG Plus	80
General	80
Solar Module Ground at Negative Pole	80
Solar Module Ground at Negative Pole for Fronius IG Plus	80
Safety	81
Setting Inverters for Grounded Solar Modules	81
Solar Module Ground: Inserting Fuses	81
Opening Fronius IG Plus for Service/Maintenance	82
Solar Module Ground at Positive Pole: Connecting Solar Module Strings	83
General	83
Cable Cross Section of Solar Module Strings	83
Solar Module Ground at Positive Pole: Connecting Solar Module Strings	83
Selecting String Fuses	85
Using String Fuses in Fronius IG Plus	86
Criteria for the Proper Selection of String Fuses	87
General	87
Criteria for the Proper Selection of String Fuses	87
Effects of using underrated fuses	87
Fuse Recommendations - Application Example	87
Fuses	88

Solar Module Ground at Positive Pole: Connecting Solar Module Strings with a Cable Cross Section > 16 mm ²	89
General	89
Additional Required Components	89
Solar Module Ground at Positive Pole: Connecting Solar Module Strings with a Cable Cross Section > 16 mm ²	90
Solar Module Ground at Positive Pole for Fronius IG Plus	93
General	93
Solar Module Ground at Positive Pole	93
Solar Module Ground at Positive Pole for Fronius IG Plus	93
Safety	94
Setting Inverters for Grounded Solar Modules	94
Solar Module Ground: Inserting Fuses	94
Opening Fronius IG Plus for Service/Maintenance	95
Closing Fronius IG Plus	96
Closing Fronius IG Plus	96
Inserting Option Cards	97
Suitable Option Cards	97
Safety	97
Opening Fronius IG Plus	97
Inserting Option Cards	98
Closing Fronius IG Plus	98
Solar Net and Data Interface	99
Example	100
Commissioning	101
Factory Configuration	101
Commissioning	101

Troubleshooting and Maintenance 103

Status Diagnosis and Troubleshooting	105
Display of Status Messages	105
General Status Messages	105
Total failure	105
Status Messages for a Fronius IG Plus with Several Power Modules	106
Status Messages - Class 1	107
Status Messages - Class 3	109
Status Messages - Class 4	111
Status Messages - Class 5	117
Customer Service	120
Maintenance	121
Safety	121
General	121
Operation in Environments with a Strong Formation of Dust	121
Opening Fronius IG Plus for Service/Maintenance	122
Replacing String Fuses	123
Safety	123
Before Installing	123
Replacing Fuses	124
Finally	124

Appendix

125

Technical Data 127

- Fronius IG Plus 35 127
- Fronius IG Plus 50 128
- Fronius IG Plus 70 129
- Fronius IG Plus 100 130
- Fronius IG Plus 120 131
- Fronius IG Plus 150 132

Relevant Standards and Directives 133

- CE Mark 133
- Parallel Operation of In-Plant Power Generation Systems 133
- Switching to Prevent Stand-alone Operation 133
- Grid Failure 133
- Relevant Standards and Directives 133

Warranty and Disposal 134

- Warranty Provisions and Liability 134
- Exclusions to Warranty Claims 134
- Warranty Claim Requirements 134
- Scope of Warranty 134
- Warranty Period 135
- Proof of Warranty 135
- Disposal 135

Operation

Operator and Equipment Protection

Safety



WARNING! If the equipment is used or tasks are carried out incorrectly, serious injury or damage may result. The Fronius IG Plus should only be installed by trained service personnel in accordance with technical regulations. It is essential that you read the „Safety Regulations“ chapter before installation or before carrying out any maintenance work.

Operator and Equipment Protection

The design and functionality of the Fronius IG Plus provides maximum safety for both installation and operation.

The Fronius IG Plus provides operator and equipment protection through:

- a) galvanic isolation
- b) monitoring the mains network

Galvanic Isolation

The Fronius IG Plus is equipped with a high frequency transformer that provides galvanic isolation between the DC side and the grid, thus ensuring the highest possible safety.

Monitoring the mains network

In the event of abnormal conditions in the mains network (e.g. grid disconnection or interruption), the Fronius IG Plus will stop working immediately and stop feeding current into the grid.

Mains network monitoring is carried out using:

- Voltage monitoring
- Frequency monitoring

The Fronius IG Plus in the Photovoltaic System

General	The Fronius IG Plus solar inverter is a highly sophisticated link between the solar modules and the public grid.
Tasks	The main tasks of the Fronius IG Plus include: <ul style="list-style-type: none">- Converting DC to AC current- Fully automatic operational management- Display function and data communication
Converting DC to AC current	<p>The Fronius IG Plus converts the direct current (DC) generated by the solar modules into alternating current (AC). This alternating current is fed synchronously into your house's mains voltage network or the public grid.</p> <p>Important The Fronius IG Plus was developed exclusively for use with grid-connected photovoltaic systems. Power generation independent from the public grid is not possible.</p>
Fully Automatic Operational Management	<p>The operation of Fronius IG Plus is fully automatic. As soon as enough power is being generated after sunrise, the control module begins monitoring the mains voltage and frequency. When the sunlight has reached a sufficient level of irradiation, the photovoltaic inverter will start the feed in operation.</p> <p>The Fronius IG Plus operates in such a way as to ensure that the maximum power possible is obtained from the solar modules. This function is called „Maximum Power Point Tracking“ (MPPT).</p> <p>As soon as the available power is no longer sufficient to feed into the grid after dusk, the Fronius IG Plus disconnects completely from the grid and shuts down. All settings and data are saved.</p>
Display Function and Data Communication	The display on the inverter is the interface between the inverter and the operator. The design of the display is geared towards simple operation and making system data available as long as the inverter operates.

Display Function and Data Communication

(continued)

The Fronius IG Plus has a basic function for providing minimum and maximum values on a daily and total basis. These values are shown on the display.

The display also provides the option of showing the following weather data:

- 2 different temperature values (e.g. temperature at the solar modules, outside temperature in the shade)
- Solar radiation

A wide range of data communication elements also enables a multitude of logging and display options.

System Upgrades

The Fronius IG Plus is designed for various system upgrades, e.g.:

- Upgrades that enable Fronius IG Plus to communicate with external system upgrades as well as other inverters
- Datalogger (for using a PC to record and manage data from your photovoltaic system), includes Datalogger and modem interface
- Various large-format displays
- Living room display
- Actuators (e.g.: relays, alarms)
- Sensors (e.g. for temperature, irradiance, energy measurement, etc.)
- Interface cards

System upgrades are available as plug-in cards.

Inverter Cooling using Forced-air Ventilation

The temperature-controlled and speed-controlled ball bearing fan of the Fronius IG Plus provides:

- optimal inverter cooling
- higher efficiency
- cooler components, thus improving service life
- lowest possible energy consumption and lowest possible noise level

Power Derating

In the event that the heat cannot be dissipated even with the fan working at maximum speed, a process known as power derating is initiated in order to protect the Fronius IG Plus (e.g. in switch boxes that do not have an appropriate heat dissipation system).

A power derating system briefly restricts the output from the Fronius IG Plus in order to prevent the temperature from exceeding the permissible value.

The Fronius IG Plus will continue to operate without any downtimes for as long as possible.

Fronius IG Plus Device Description

Controls and Indicators

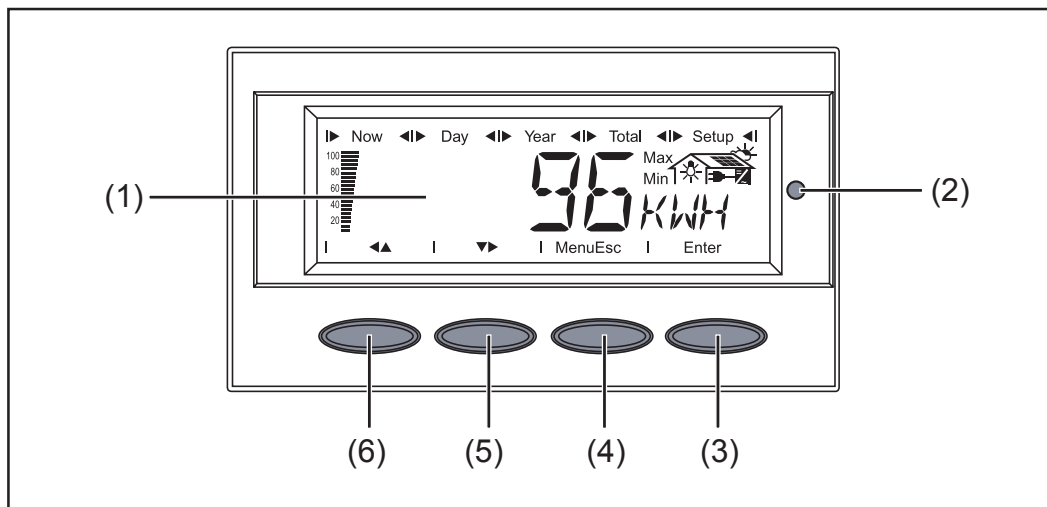

Controls and Displays on the Fronius IG Plus

Item	Function
(1)	Display for displaying values, settings and menus
(2)	LED operating status for displaying the operating status
(3)	'Enter' key for confirming a selection
(4)	'Menu / Esc' key for scrolling through menu options for exiting the Setup menu
(5)	'Down/Right' key depending on the selection: for navigating down for navigating right
(6)	'Left/Up' key depending on the selection: for navigating left for navigating up

Display

Power for the display comes from the solar modules via safety-low voltage. The display is therefore available during daylight hours.

Important The Fronius IG Plus display is not an aligned measuring instrument. A slight deviation of a few percent points is intrinsic to the system. An aligned meter will be required to make calculations for the utility company.

Display
(continued)

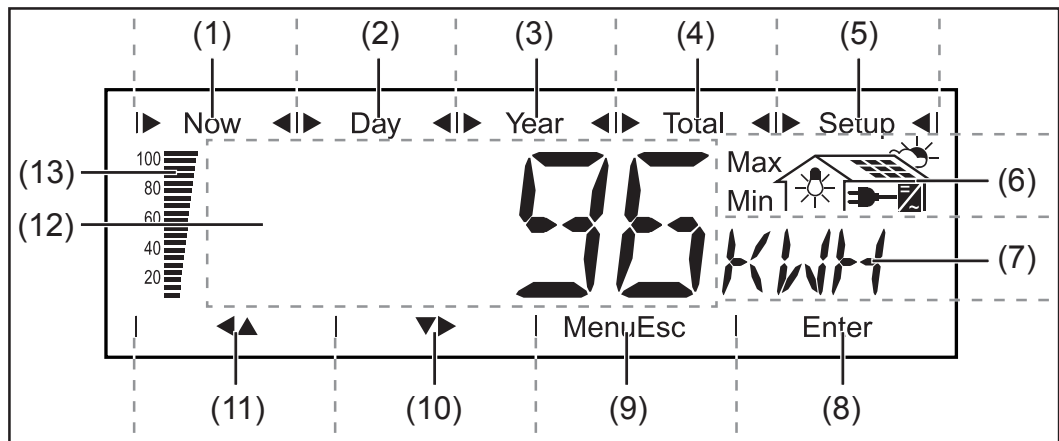

Display

Item	Function
(1)	Icons for the 'Now' display mode
(2)	Icons for the 'Day' display mode
(3)	Icons for the 'Year' display mode
(4)	Icons for the 'Total' display mode
(5)	Icons for the 'Setup' display mode
(6)	Icons for operating conditions

Max The value shown represents the maximum period of time in question (depending on which display mode is selected).

Min The value shown represents the minimum period of time in question (depending on which display mode is selected).

Important The minimum and maximum values displayed do not represent the absolute extreme values because data is only recorded at 2-second intervals.



... appears when displaying values transmitted by the energy meter (optional)



... appears when displaying values directly associated with the solar module



... appears when displaying values associated with environmental conditions such as solar radiation and temperature (optional)



... appears when displaying values directly associated with the public grid



... appears when displaying values directly associated with the Fronius IG Plus

Display
(continued)

Item	Function
(7)	Area for display unit displays the unit assigned to the display value
(8)	Icon for the 'Enter' key
(9)	Icons for the 'Menu/Esc' key
(10)	Icons for the 'Down/Right' key
(11)	Icons for the 'Left/Up' key
(12)	Area for the display value shows the display value
(13)	Segment bar (not active during setup) displays the current power feeding into the grid independent of the selected display mode. Displayed as a percentage of the maximum power that the photovoltaic inverter is capable of.

Startup Phase

Once the Fronius IG Plus switches on automatically it runs a self-test. After this, the public grid is tested. This test can take from several seconds up to several minutes depending on local regulations. The Operating Status LED is yellow during the start-up phase.

Test Procedure

1. Segment test
All display elements will illuminate for approximately one second

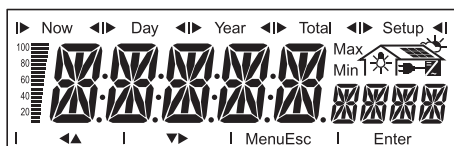

2. Self-test of the Fronius IG Plus' main components
 - The Fronius IG Plus goes through a virtual checklist
 - The display will show 'TEST' as well as the component currently being tested (e.g. 'LED')

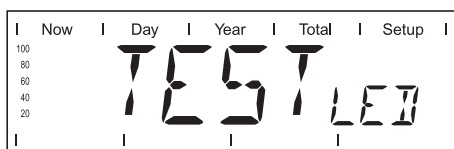

3. Synchronization with the grid
 - 'WAIT_{PS}' is displayed, the inverter icon blinks: Fronius IG Plus is waiting for all the power modules on the grid to be ready. This process is dependent on the DC voltage.

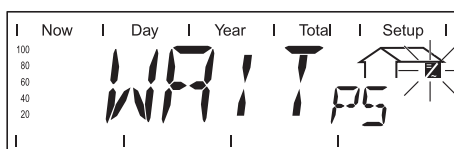

Test Procedure
(continued)

- Next, the display will show „SYNC_{AC}“, the grid icon will blink

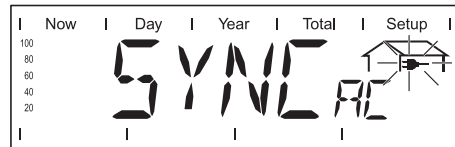

4. Only for the Italy country setup (ITA setup): Auto test
 - The Fronius IG Plus tests the grid monitoring function
 - The display alternates between 'AUTOTEST' and 'AUTOOK'

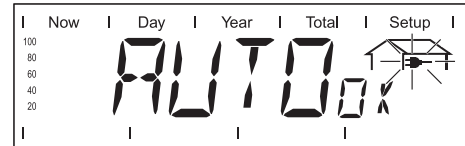
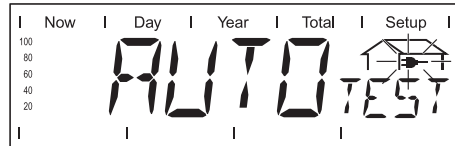

5. Startup test
 - Before the Fronius IG Plus begins feeding power into the grid, grid conditions are tested according to local regulations
 - 'STARTUP' will appear on the display

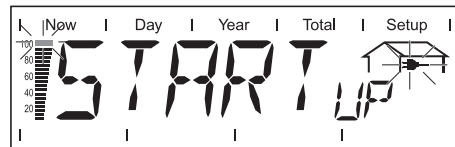

The startup test can take anywhere from just a few seconds up to several minutes depending on local regulations. Progress is indicated by a vertical segment bar which reduces in size from top to bottom.

Two of the previously flashing dividing marks disappear for every 10% of the total duration of the startup test that has been completed.

6. Grid power feed-in
 - Once the tests have been completed the Fronius IG Plus starts feeding power into the grid
 - The display shows the current power feeding into the grid
 - The Operating Status LED is illuminated green and the Fronius IG Plus is in operation



LED Operating Status

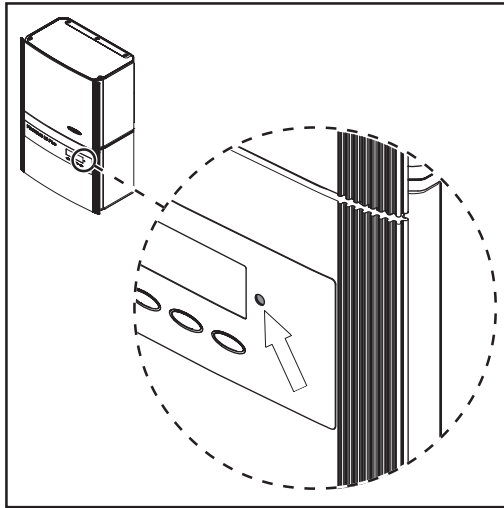

Position of Operating Status LED on the Fronius IG Plus

The Operating Status LED changes color according to the operating status:

LED Operating Status	Explanation
lights up green	The LED stays lit after the automatic startup phase of the Fronius IG Plus as long as power is being fed into the grid. The photovoltaic system is working correctly.
flashing green	The photovoltaic system is working correctly, a status message is on the display. When a status message is displayed, you can find out what it indicates by going to the 'Maintenance and Service' chapter, 'Status Diagnosis and Troubleshooting' section. The status message can be acknowledged by pressing the 'Enter' key.
lights up orange	The Fronius IG Plus will enter its automatic startup phase as soon as the solar panels start providing sufficient power after sunrise
flashing orange	A warning appears on the display or the Fronius IG Plus has been switched to standby mode in the setup menu (= power feed-in is switched off manually) Power feed-in is resumed automatically after the next sunrise. When the orange LED is flashing, power feed-in can be started manually at any time (see section entitled "The Setup Menu")

LED Operating Status
(continued)

LED Operating Status	Explanation
lights up red	General status: Display of corresponding status message on the Display
remains dark	No connection to solar modules No output from module due to an absence of daylight

A list of corresponding status messages, causes, and troubleshooting measures can be found in 'Maintenance and Service' chapter in the 'Status Diagnosis and Troubleshooting' section.

Navigating Around the Display

Activating Display Illumination

1. Press any key.

The display illumination will activate.

If no key is pressed for 30 seconds, the display illumination will go off again.

You can set the display to illuminate all the time or turn off the display illumination completely in the Setup menu.

Accessing Menus

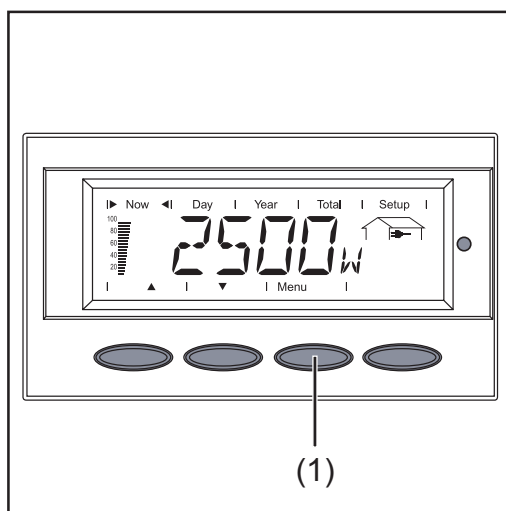

Accessing Menus

1. Press the „Menu“ button (1)

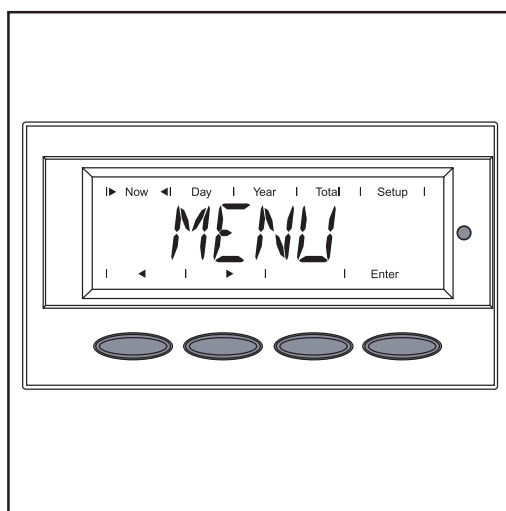

Menu Levels

‘Menu’ will appear on the display

The Fronius IG Plus is now in the menu level.

- From the menu level you can
- set the desired display mode
 - access the Setup menu

Selecting a display mode

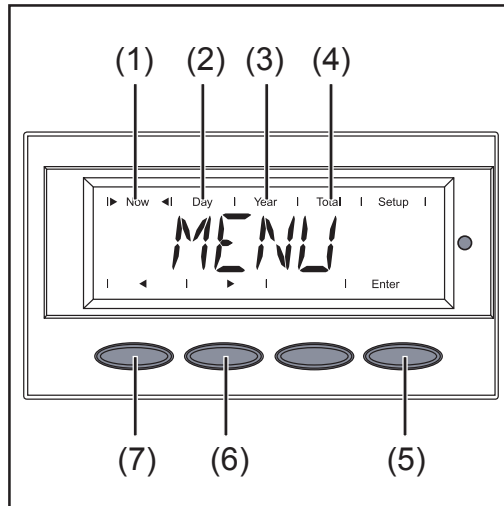

Selecting a Display Mode

1. Accessing Menu Levels
2. Use the 'left' (7) or 'right' (6) keys to select your preferred display mode (1) - (4)
3. Press 'Enter' (5)

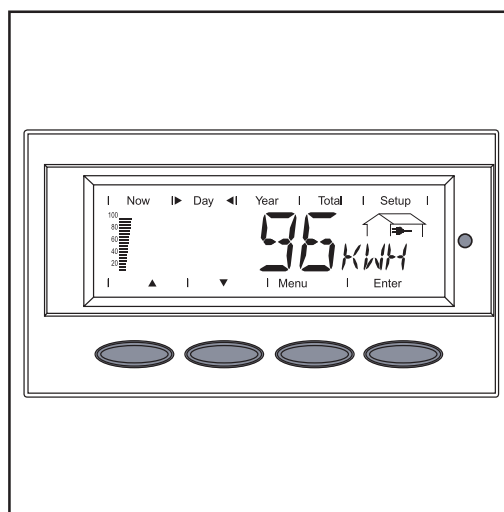

Example: 'Day' display mode

The selected display mode is shown

Important The 'Year' menu option is supported only when the optional Datalogger is connected. This system upgrade includes a real-time clock.

Scrolling Between Display Values

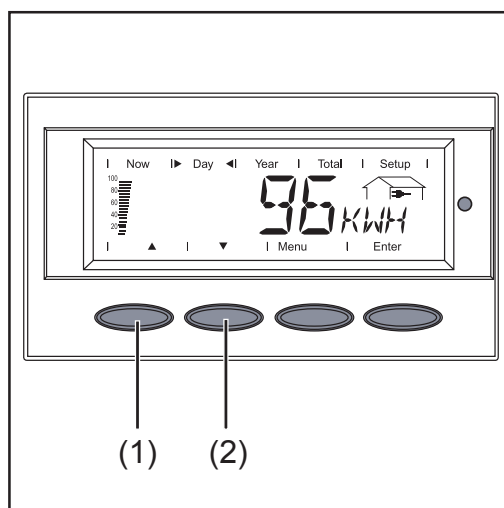



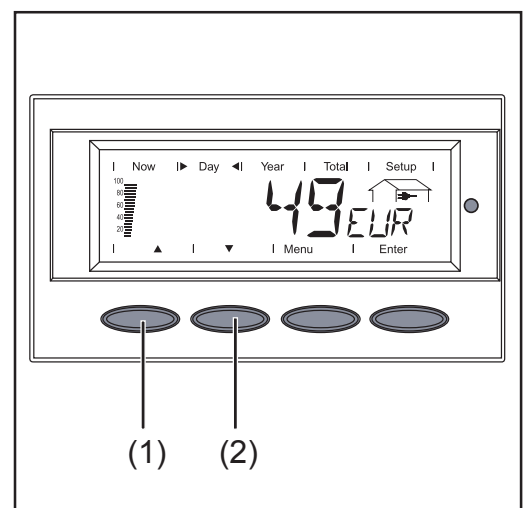





















Example: 'Fed-in Energy' display value



Example: 'Earnings' display value

1. Selecting a desired display mode
2. Scroll through the available display values using the 'Up' (1) and 'Down' (2) keys

Overview of Display Values

Display mode	Icon	Unit	Optional	Display value
'Now'		W	-	Power fed into the grid
		V	-	Mains voltage
		A	-	Current fed in
		Hz	-	Mains frequency
		V	-	Solar module voltage
		A	-	Solar module current
		°C / °F	x	Solar module temperature
		MOhm	-	Insulation resistance
		W	x	Output recorded by energy meter
		°C / °F	x	Ambient temperature
		W/m ²	x	Solar radiation
		HH:MM	x	Time
'Day'		kWh / MWh	-	Energy fed into the grid
		Currency	-	Earnings
'Year'		kg/t	-	CO ₂ reduction
'Total'		W	-	Max. fed-in power
		V	-	Max. mains voltage
		V	-	Min. mains voltage
		V	-	Max. solar module voltage
		kwh / MWh	x	Energy recorded by energy meter
		°C / °F	x	Max. solar module temperature
		°C / °F	x	Min. solar module temperature
		°C / °F	x	Max. ambient temperature
		°C / °F	x	Min. ambient temperature
		W/m ²	x	Max. solar radiation
		HH:MM	-	Fronius IG Plus operating hours

x Optional

If the required option card is not available, 'N.A.' (not applicable) will be displayed.

Display Modes

Display Modes The following display modes are available for the Fronius IG Plus:

„Now’ display mode Displays real-time values

‘Day’ display mode Displays values for power fed into the grid during that day

‘Year’ display mode Displays values for power fed into the grid during the current calendar year (only in conjunction with an optional Datalogger)

‘Total’ display mode Displays values for power fed into the grid since the Fronius IG Plus was originally commissioned.

Overview The ‘display modes’ are composed of the following sections:

- Display values in ‘Now’ display mode
- Display values in ‘Day / Year / Total’ display mode

Display Values in 'Now' Display Mode

Selecting 'Now' Display Mode

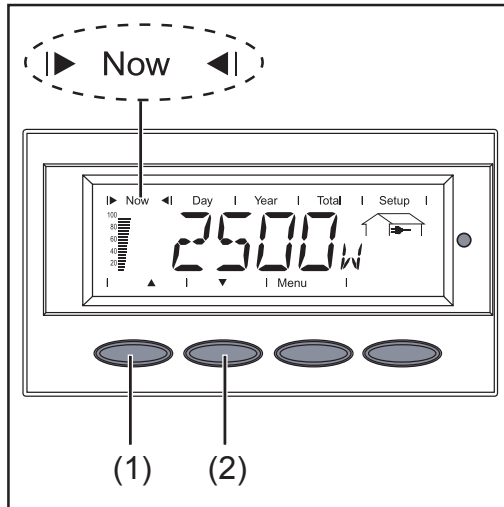

First display values in the 'Now' display mode

1. Select 'Now' display mode

The first display value appears in the 'Now' display mode

2. Use the 'Down' (2) key to scroll to the next display value

Scroll back using the 'Up' key (1)

Display Values in 'Now' Display Mode

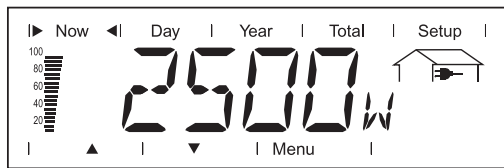

Power fed into the mains

Power (in watts) currently being fed into the grid

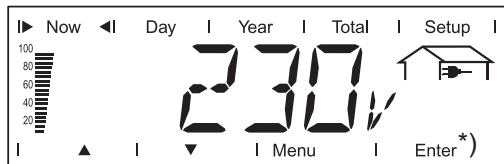

Mains voltage

(in volts)

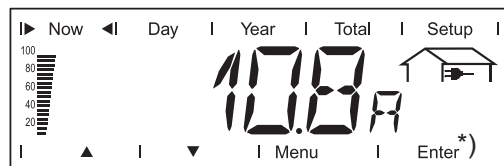

Current fed in

Current (in amperes) currently being fed into mains

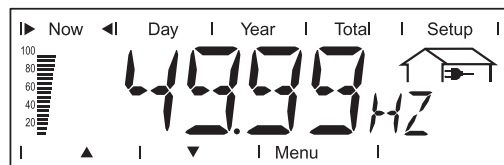

Mains frequency

(hertz)

*) only for a multi-phase Fronius IG Plus

**Display Values
in 'Now' Display Mode
(continued)**

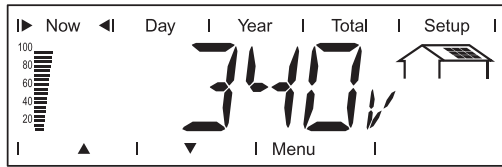

Solar module voltage
Voltage (in volts) currently present at the solar modules

The voltage displayed while power is being fed into the grid corresponds to the so-called MPP voltage (MPP = maximum power point).

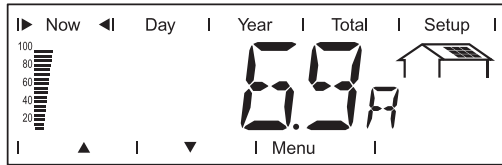

Module current
Current (in amperes) that is currently being supplied by the solar modules

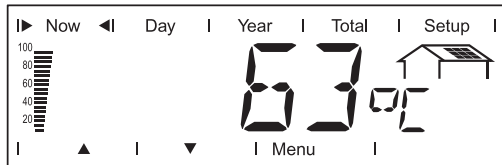

Module temperature (optional)
Temperature at the solar modules (°C can be changed to °F in the setup menu, temperature sensor no. 1, sensor card option)

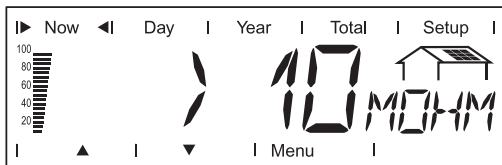

Insulation resistance of the photovoltaic system
(MOhm)
For ungrounded solar modules



WARNING! An electrical shock can be fatal. The positive and negative poles of the photovoltaic system should never be touched with an insulation resistance of < 500 kOhm. An insulation resistance of < 500 kOhm may be due to an inadequately insulated DC lead or defective solar modules. In the event that the insulation resistance is too low, you must contact your Fronius service partner.

The insulation resistance is the resistance between the positive or negative poles of the photovoltaic system and the ground potential. If an insulation resistance > 500 kOhms is shown, this means that the photovoltaic system is adequately insulated.

An insulation resistance of less than 500 kOhms indicates a error.

When the insulation resistance is less than 10 MOhms, the display differentiates between:

- negative potential and the ground (polarity sign '-')
- positive potential and the ground (polarity sign '+')



Example of display for negative potential (polarity sign '-')
Short circuit between DC lead and ground

**Display Values
in 'Now' Display Mode**
(continued)

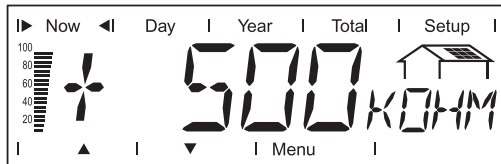

Example of display for positive potential (polarity sign '+'): Short circuit between DC+ lead and ground

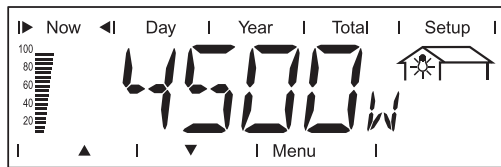

Power taken out of the grid (optional)
Current consumption (in watts, optional sensor card)

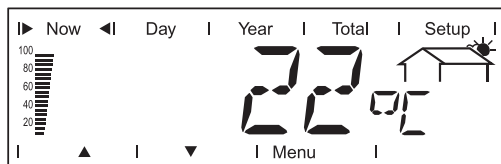

Ambient temperature (optional)
(°C can be changed to °F in the Setup menu, temperature sensor no. 2, sensor card option)

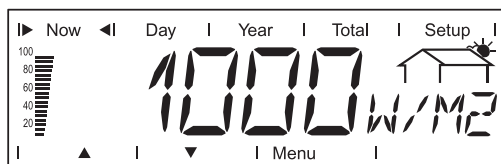

Solar radiation (optional)
Insolation power coming down on each square meter (watts/m², optional sensor card)

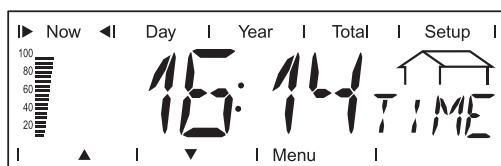

Time (optional Datalogger)
When the time on the Fronius IG Plus or a system upgrade is changed, this changes the time on all connected devices via Solar Net.

Options

If the required option card is not available, 'N.A.' (not applicable) will be displayed.

Display Values in 'Day / Year / Total' Display Mode

General

The time when the Fronius IG Plus is turned on signals the start of the day. If the DC-in lead is disconnected, the following values will be reset for the 'Day' display mode after the unit has been restarted:

- Earnings (currency can be selected)
- CO₂ reduction (kg)
- Max. power fed in (watts)
- Max. mains voltage (volts)
- Min. mains voltage (volts)
- Energy taken out of the grid (kWh)
- Fronius IG Plus operating hours

If the Datalogger option is available, the display values are valid for the entire calendar day.

Selecting 'Day / Year / Total' Display Mode

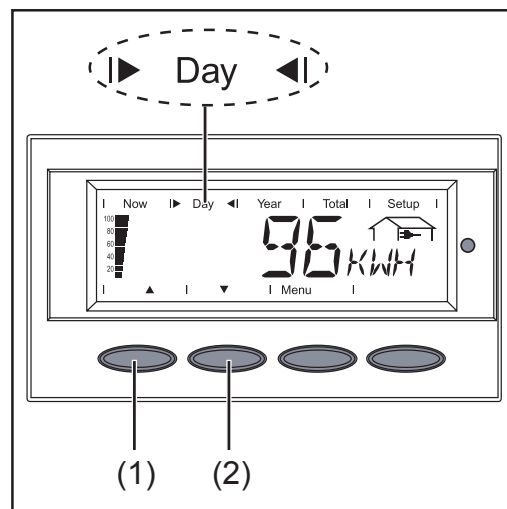

First display values in the 'Day' display mode

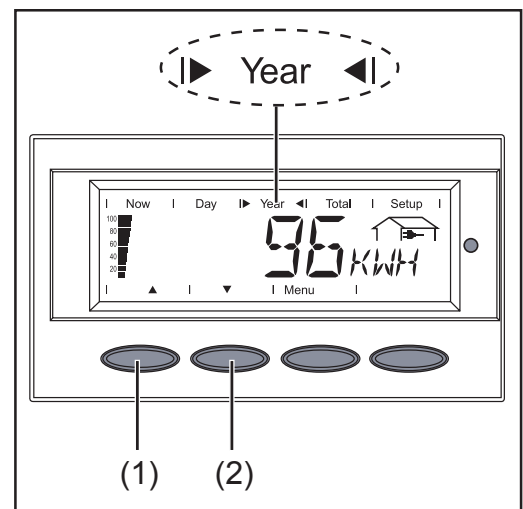

First display values in the 'Year' display mode

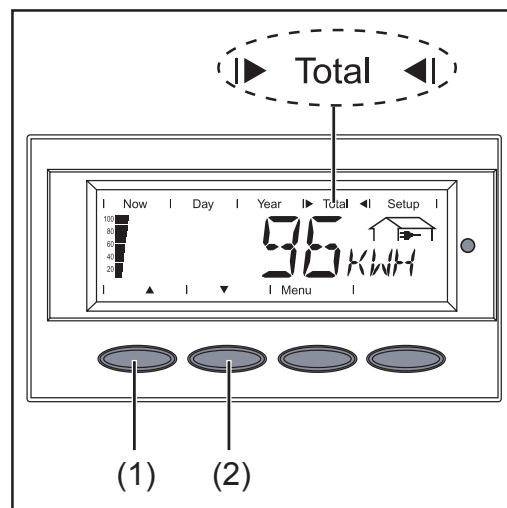

First display values in the 'Total' display mode

1. Selecting 'Day / Year / Total' Display Mode

The first display values in the 'Day / Year / Total' display mode

2. Use the 'Down' (2) key to scroll to the next display value

Scroll back using the 'Up' key (1)

Display Values in 'Day / Year / Total' Display Mode

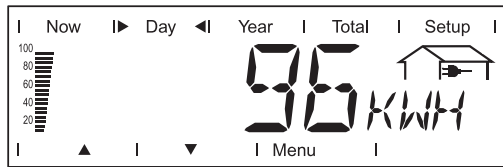

Energy fed into the grid

Energy fed into the grid over the period of time in question (kWh / MWh)

There may be discrepancies with values displayed on other measuring instruments because of differences in methods of measurement. The only binding display values for the energy fed into the grid are those calculated by the aligned measuring device provided by the utility company.

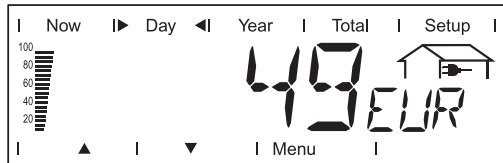

Earnings

Amount of money earned during the period of time in question (currency can be selected in the Setup menu)

As with energy fed in, here too, there may be discrepancies with other measured values.

The 'Setup Menu' chapter describes how to select a currency and charge the rate. The factory setting depends on the respective country settings.

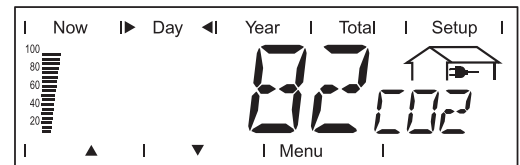
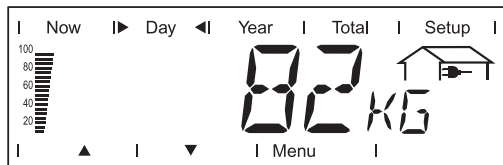

CO₂ reduction

Saved CO₂ emissions during the respective time period (kg/t, t = time duration)

The display unit will alternate between 'kg' and 'CO₂.'

The value for the CO₂ reduction corresponds to the CO₂ emissions that would have been emitted by a caloric power plant generating the same amount of energy.

The factory setting is 0.53 kg / kWh (source: DGS - the German Society for Solar Energy).



Max. fed in power

largest amount of power (W) fed into the grid over the period of time in question

**Display Values
in 'Day / Year /
Total' Display
Mode**
(continued)

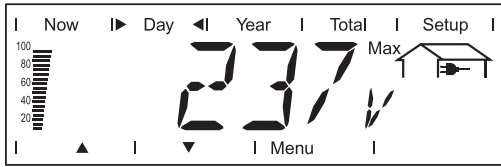

Max. mains voltage
highest mains voltage (V) measured during the time in question

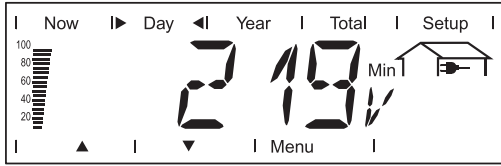

Min. mains voltage
lowest mains voltage (V) measured during the time in question

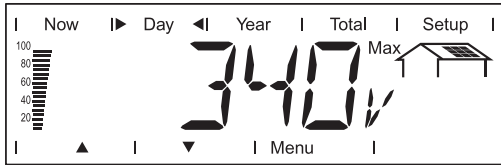

Max. solar module voltage
highest solar module voltage (V) measured during the time in question

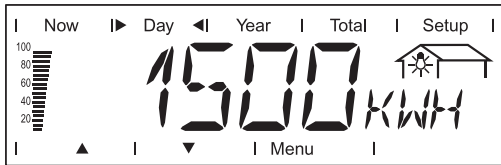

Energy recorded by energy meter (optional)
energy used during the time in question (kWh / MWh, energy meter option)

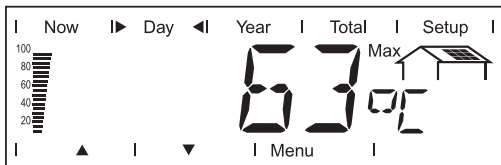

Max. solar module temperature (optional)
highest temperature measured at the solar modules during the time in question (°C can be changed to °F in the setup menu, temperature sensor no. 1, sensor card option)



Min. solar module temperature (optional)
lowest temperature measured at the solar modules during the time in question (°C can be changed to °F in the setup menu, temperature sensor no. 1, sensor card option)



Max. ambient temperature (optional)
highest temperature measured during the time in question (°C can be changed to °F in the setup menu, temperature sensor no. 2, sensor card option)

**Display Values
in 'Day / Year /
Total' Display
Mode**
(continued)

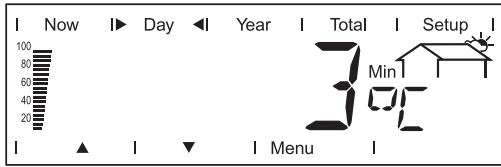

Min. ambient temperature (optional)

lowest temperature measured during the time in question ($^{\circ}\text{C}$ can be changed to $^{\circ}\text{F}$ in the setup menu, temperature sensor no. 2, sensor card option)

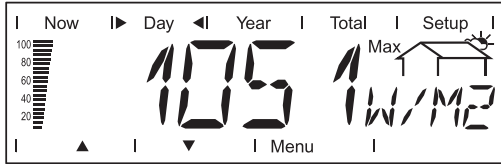

Max. solar radiation (optional)

highest solar radiation measured during the time in question (W/m^2 , sensor card option)

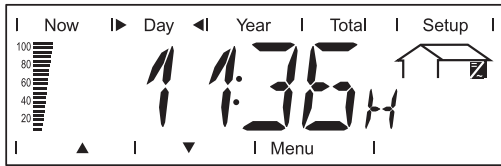

Operating hours

Number of operating hours completed by the Fronius IG Plus (HH:MM)

The operating hours are shown in hours and minutes up to 999 hours and 59 minutes ('999:59'). After that, only the hours are shown.

Although the Fronius IG Plus does not operate during the night, the data required by the optional sensor card is logged and stored 24 hours a day.

Options

If the required option card is not available, 'N.A.' (not applicable) will be displayed.

The Setup Menu

Default Settings

The Fronius IG Plus is pre-configured and ready to use. There is no need to make any initial settings before using it to feed power into the grid. This is a fully-automated process.

The Setup menu enables you to change the default settings for the Fronius IG Plus to meet user specifications and requirements.

Opening the setup menu

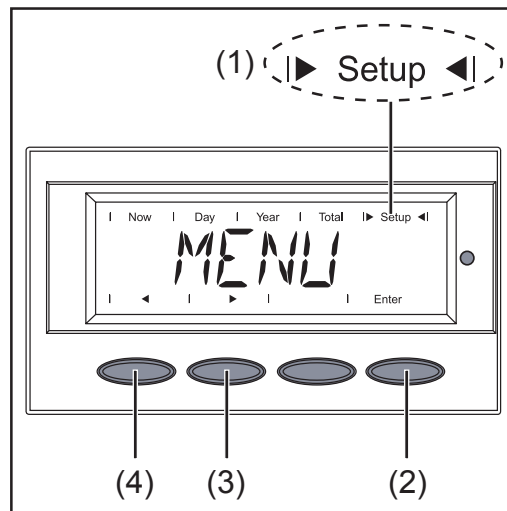

'Setup' menu level selected

1. Switch to the menu level (press the 'Menu' key)
2. Select the 'Setup' (1) mode using the 'Left' (4) or 'Right' (3) keys
3. Press 'Enter' (2)

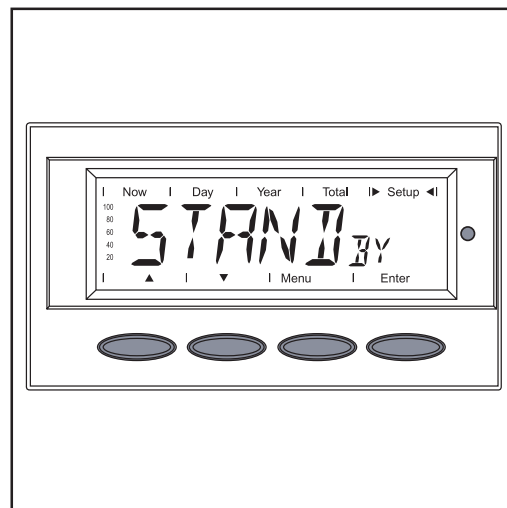

'STANDBY' menu option

The Setup Menu's first menu option 'STANDBY' will be displayed.

Scrolling through Menu Options

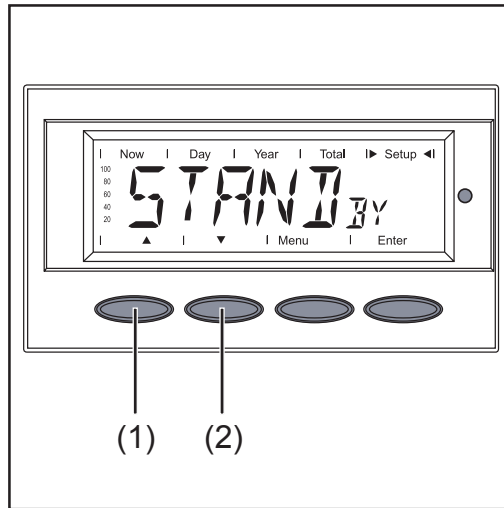

Example: 'STANDBY' menu option

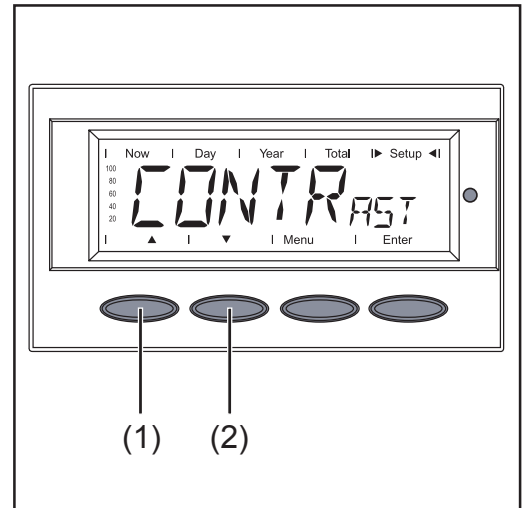

Example: 'CONTRAST' menu option

1. Open the setup menu
2. Scroll through the available menu options using the 'Up' (1) and 'Down' (2) keys

Menu Options in the Setup Menu

STANDBY

Manual activation / deactivation of Standby operation using the 'Enter' key

Unit	-
Setting range	Enter
Factory setting	'Standby' deactivated

- The power electronics are switched off in standby mode. No power is fed into the grid.
- The Operating Status LED flashes orange.
- The orange flashing LED goes off after dusk.
- After sunrise the following day, power being fed into the grid is resumed automatically (LED will light up green after the startup phase).
- When the LED is flashing orange, the grid feed can be resumed at any time (deactivate 'Standby').

CONTRAST

Adjusts the contrast on the LCD display

Unit	-
Setting range	0 - 7
Factory setting	7

Because contrast is temperature-dependent, changing environmental conditions can require the setting of the 'Contrast' menu option.

**Menu Options
in the Setup
Menu**
(continued)

LIGHT_{MODE}

Initial setting for display illumination.

Unit	-
Setting range	AUTO / ON / OFF
Factory setting	AUTO

AUTO: The display illumination is switched off if no key is pressed for 30 seconds.

ON: The display illumination remains on permanently while power is being fed into the grid.

OFF: The display illumination is permanently switched off.

Important! The 'LightMode' setting only relates to the display's background illumination. There is no need to switch off the display itself as it uses only a small amount of energy (less than one mW (1/1000 W)).

CASH

Currency and charge rate setting for the energy fed into the grid

Unit	-
Display area	Currency / Charge rate/kWh
Factory setting	(depending on the country setting)

IG no.

Sets the number (= address) of the Fronius IG Plus in a system with several solar inverters

Unit	-
Setting range	01 - 99 (100. Fronius IG Plus = 00)
Factory setting	01

Important! Each Fronius IG Plus must be assigned its own address when connecting several inverters in a data communications system.

DAT_{COM}

Controls a data connection, activates the signal card, resets the Personal Display Card and Interface Card

Unit	-
Setting range	Displays OK _{COM} ; SIGCD _{TEST} / PDCD _{RST} / IFCD _{RST}
Factory setting	-

TIME

Time and date setting

Unit	DDMMYYYY, HH:MM
Display area	Date / Time
Factory setting	-

The 'Time' menu option is only supported when the optional Datalogger is connected.

**Menu Options
in the Setup
Menu**
(continued)

STATE_{PS}

Status display for power modules, the last error that occurred can be displayed

Important Due to the low level of insolation early in the morning and in the evening, the status messages 306 (power low) and 307 (DC low) are displayed routinely at these times of day. These status messages do not indicate any kind of fault.

VERSION

Shows the version number and serial number of the IG Brain unit and the power module.

Unit	-
Setting range	MAIN _{CTRL} / LCD / PS (PS00, PS01, PS02)
Factory setting	-

Setting and Displaying Menu Options

General Menu Option Settings

1. Open the setup menu
2. Select the desired menu option
3. Press the 'Enter' key
4. Use the 'Up' and 'Down' keys to change the value of the menu option
5. Press the 'Enter' key - the changed values will be saved in the menu option
6. Press the 'Esc' key to exit the menu option

Setting the 'STANDBY' Menu Option

Activate 'STANDBY' - manual deactivation of the grid feed:

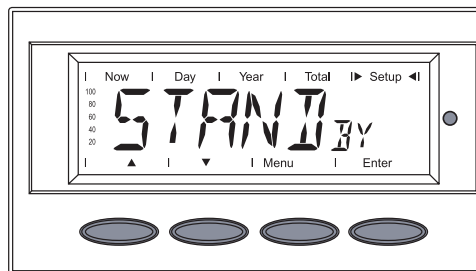

1. Select the 'STANDBY' menu option
2. Press the 'Enter' key

The standby mode will activate (manual deactivation of the grid feed).

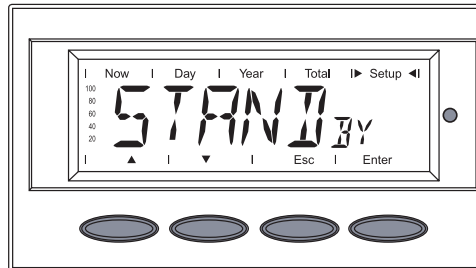

The Operating Status LED flashes orange.

The display switches between ...

'STANDBY' and

'ENTER'

3. Press the 'Esc' to exit the 'STANDBY' menu option

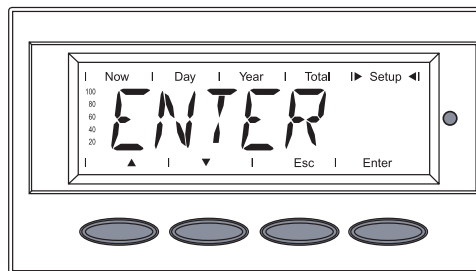

Restoring the grid feed:

1. Select the 'STANDBY' menu option
2. Press the 'Enter' key

The Fronius IG Plus will switch to the Startup phase.

After a successful startup, the Operating Status LED will be green. The current power feed will be displayed.

Setting the 'CONTRAST' menu option

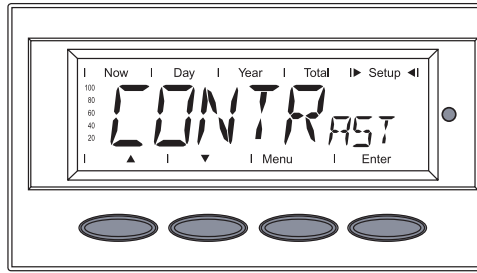

1. Select the 'CONTRAST' menu option
2. Press the 'Enter' key

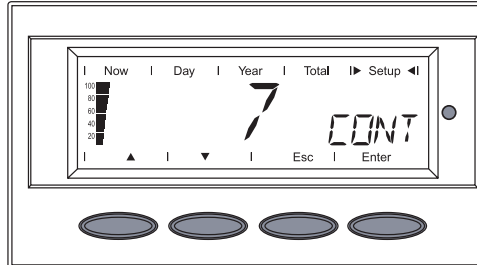

Setting '7' for the highest possible contrast will be displayed

3. Use the 'Up' and 'Down' keys to select the desired level of contrast
▲ ▼

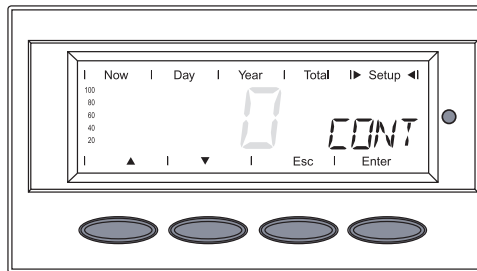
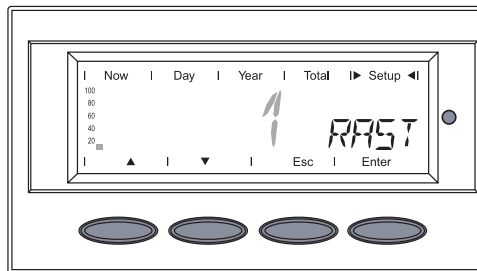

'0' setting for the lowest possible contrast

4. Press the 'Enter' key to apply the setting
5. Press the 'Esc' key to exit the 'CONTRAST' menu option

Setting the 'LIGHTMODE' menu option



1. Select the 'LIGHTMODE' menu option
2. Press the 'Enter' key



The 'AUTO' setting will be displayed

AUTO ... automatic control of display illumination

**Setting the
'LIGHTMODE'
menu option**
(continued)

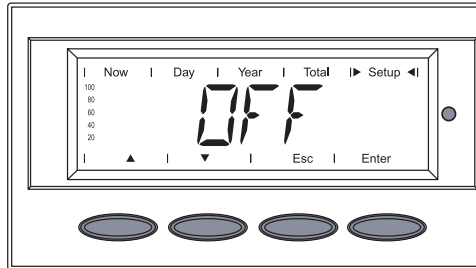
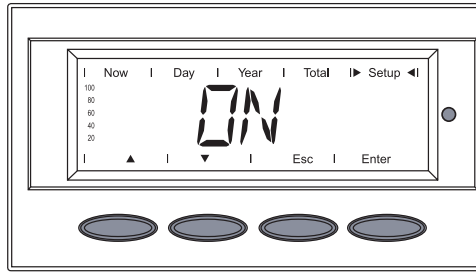

ON ... Display illumination on permanently

OFF ... Display illumination turned off

3. Use the 'Up' and 'Down' keys to select the desired setting for the display illumination
▲ ▼
4. Press the 'Enter' key to apply the setting
5. Press the 'Esc' key to exit the 'LIGHTMODE' menu option

**Setting the
'CASH' Menu
Option**

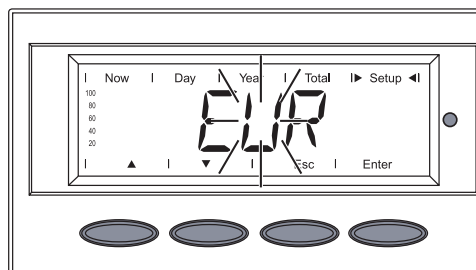
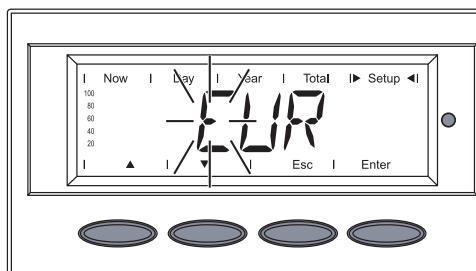
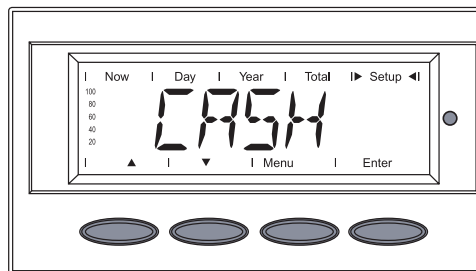

1. Select the 'CASH' menu option
2. Press the 'Enter' key

The **currency** will be displayed
factory setting = 'EUR'
The first character will now flash

3. Use the 'Up' and 'Down' keys to select a letter for the first character
▲ ▼
4. Press the 'Enter' key
The second character will now flash
5. Use the 'Up' and 'Down' keys to select a letter for the second character
▲ ▼
6. Press the 'Enter' key

**Setting the
'CASH' Menu
Option**
(continued)

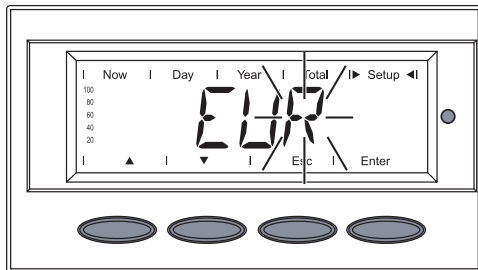

The third character will now flash

7. Use the 'Up' and 'Down' keys to select a letter for the third character
▲ ▼
8. Press the 'Enter' key

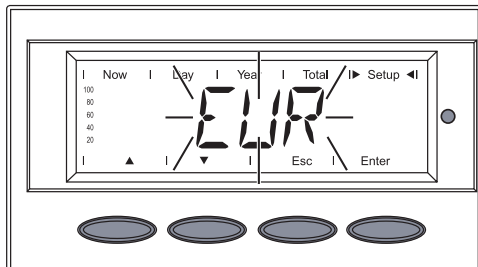

The set currency will now flash

9. Press the 'Enter' key

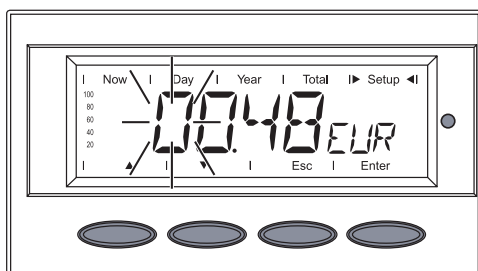

The charge rate is now displayed in kWh/currency, factory setting = 0.48 EUR / kWh
The first digit will now flash

10. Use the 'Up' and 'Down' keys to select a value for the first digit (e.g. 0)
▲ ▼
11. Press the 'Enter' key

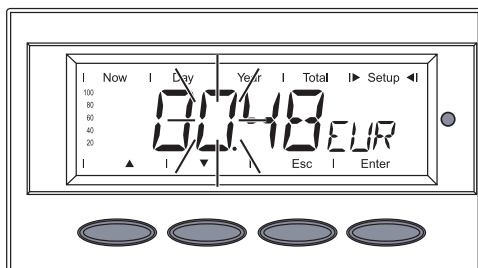

The second digit will now flash

12. Use the 'Up' and 'Down' keys to select a value for the second digit (e.g. 0)
▲ ▼
13. Press the 'Enter' key

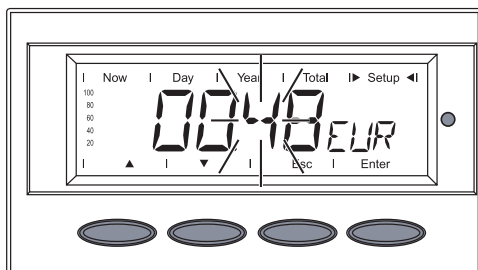

The third digit will now flash

14. Use the 'Up' and 'Down' keys to select a value for the third digit (e.g. 4)
▲ ▼
15. Press the 'Enter' key



The fourth digit will now flash

16. Use the 'Up' and 'Down' keys to select a value for the fourth digit (e.g. 8)
▲ ▼
17. Press the 'Enter' key

**Setting the
'CASH' Menu
Option**
(continued)

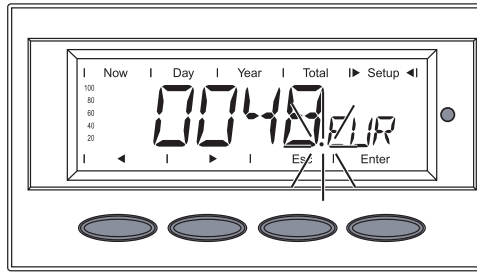

The decimal point will now flash

18. Use the 'Left' and 'Right' keys to move the decimal point to the desired location

The values that can be set range from 000.1 to 99.99

19. Press the 'Enter' key

The set charge rate will now flash

20. Press the 'Enter' key

The currency and charge rate have now been applied

21. Press the 'Esc' key to exit the 'CASH' menu option

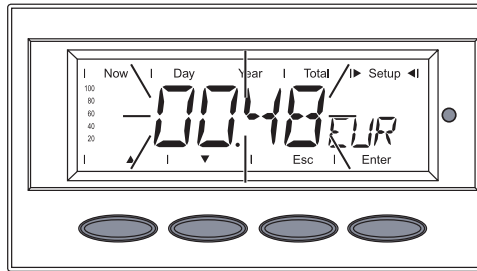

**Setting the 'IG
No.' Menu
Option**

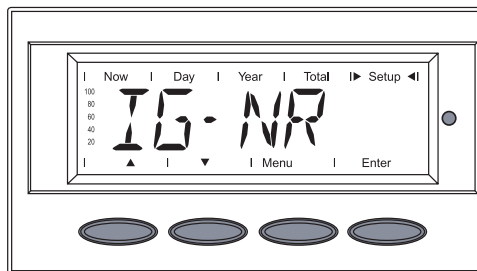

1. Select the 'IG No.' menu option
2. Press the 'Enter' key

The inverter number will appear with the first digit flashing

3. Use the 'Up' and 'Down' keys to select a number for the first digit

4. Press the 'Enter' key

The second digit will now flash

5. Use the 'Up' and 'Down' keys to select a number for the second digit

6. Press the 'Enter' key

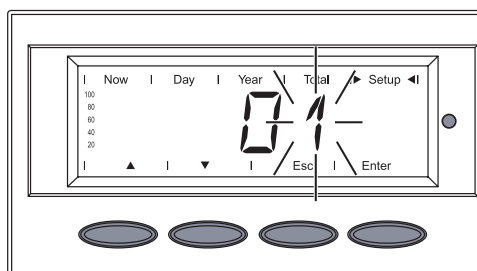
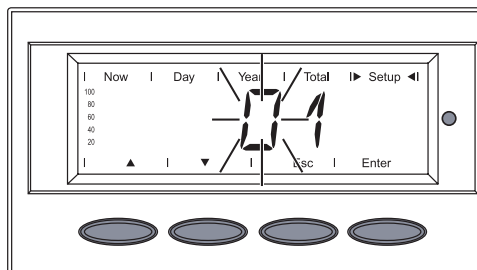

Setting the 'IG No.' Menu Option
(continued)

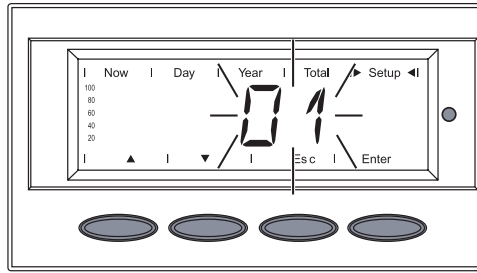

The set inverter number will now flash

7. Press the 'Enter' key

The number has been applied

8. Press the 'Esc' key to exit the 'IG No.' menu option

Setting the 'DATcom' Menu Option

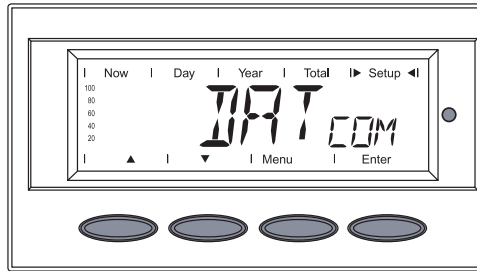

1. Select the 'DATcom' menu option
2. Press the 'Enter' key

The rest of the display depends on whether

- a data connection has been established
- a data connection is faulty or an option has not been installed

Available data connection

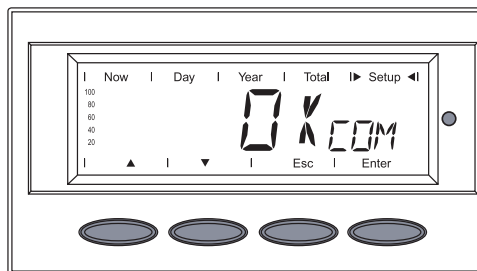

If there is a data connection, 'OKCOM' will be displayed.

3. Use the 'Down' key to initiate the 'signal card test'

'SIGCDTEST' will be displayed

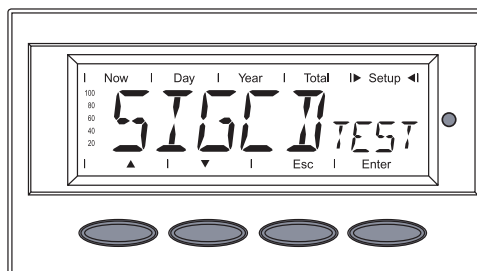

4. Press the 'Enter' key

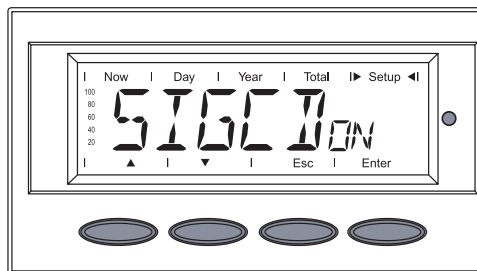

The 'signal Card Test' will start, 'SIGCDON' appears on the display

If the 'signal card' is active, it will emit an acoustic signal in confirmation.

Important If no acoustic signal is heard, the signal lines should be checked.

**Setting the
'DATcom' Menu
Option**
(continued)

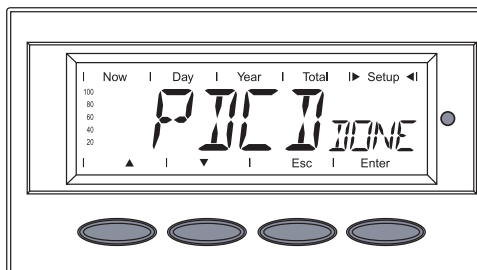
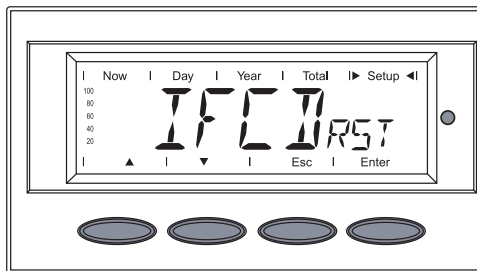
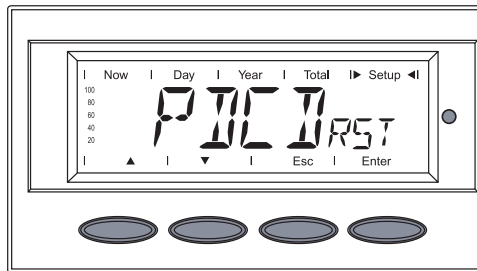
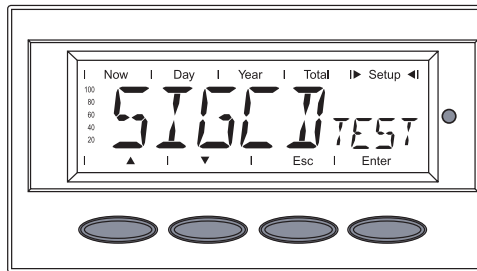

5. Press the 'Esc' key to exit the 'Signal Card Test'

'SIGCDTEST' will be displayed

6. Use the 'Down' key to select additional options:



e.g. Rest Personal Display Card ('PDCDRST') ...

... or Reset Interface Card ('IFCDRST')

7. Press the 'Enter' key

'PDCDDONE' ...

... or ...

'IFCDDONE' will be displayed

8. Press the 'Esc' key 2x to exit the 'DATCOM' menu option

Data connection faulty or DatCom is not installed

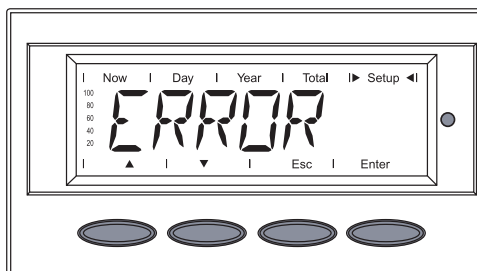

If there is a faulty data connection or options are not installed 'ERROR' will be displayed.

3. Select the respective option using the 'Down' key



**Setting the
'DATcom' Menu
Option**
(continued)

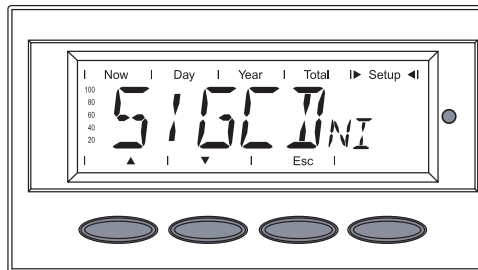

'SIGCDNI' ('Signal Card' not installed) or 'PDCDNI' ('Personal Display Card' not installed) or 'IFCDNI' ('Interface Card' not installed) will be displayed

4. Press the 'Esc' key to exit the 'DATcom' menu option

**Setting the
'TIME' Menu
Option**

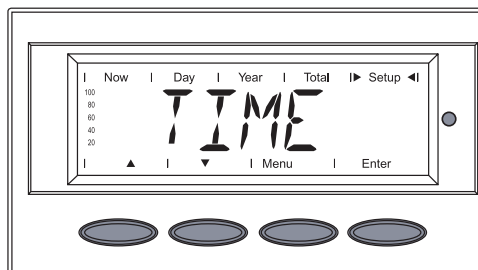

1. Select the 'TIME' menu option
2. Press the 'Enter' key

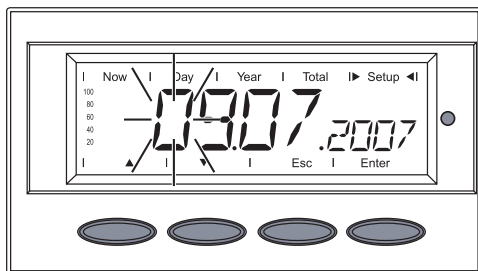

The **date** will appear (DD.MM.YYYY), the first digit for the day flashes

3. Use the 'Up' and 'Down' keys to select a value for the first day digit
▲ ▼
4. Press the 'Enter' key

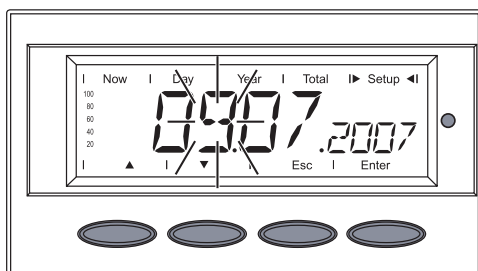

The second day digit then flashes

5. Use the 'Up' and 'Down' keys to select a value for the second day digit
▲ ▼
6. Press the 'Enter' key

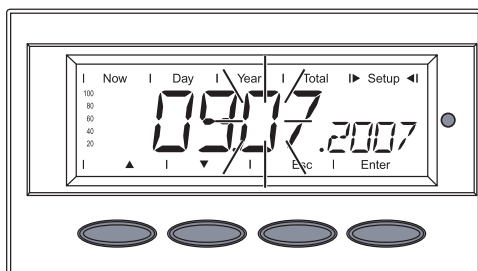

The first digit for the month flashes

7. Use the 'Up' and 'Down' keys to select a value for the first month digit
▲ ▼
8. Press the 'Enter' key

**Setting the
'TIME' Menu
Option**
(continued)

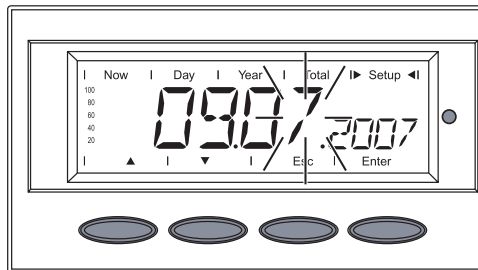

The second digit for the month flashes

9. Use the 'Up' and 'Down' keys to select a value for the second month digit
▲ ▼
10. Press the 'Enter' key

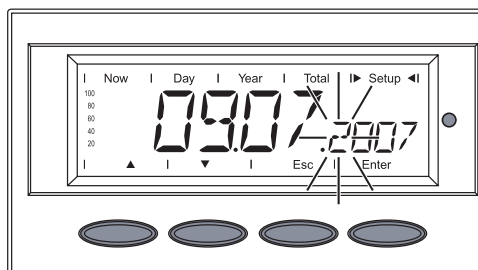

The first digit for the year flashes

11. Use the 'Up' and 'Down' keys to select a value for the first year digit
▲ ▼
12. Press the 'Enter' key

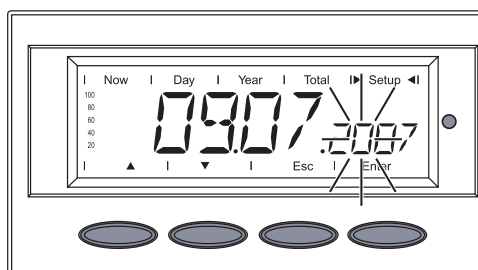

The second digit for the year flashes

13. Use the 'Up' and 'Down' keys to select a value for the second year digit
▲ ▼
14. Press the 'Enter' key

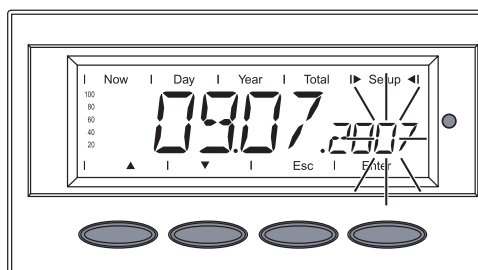

The third digit for the year flashes

15. Use the 'Up' and 'Down' keys to select a value for the third year digit
▲ ▼
16. Press the 'Enter' key

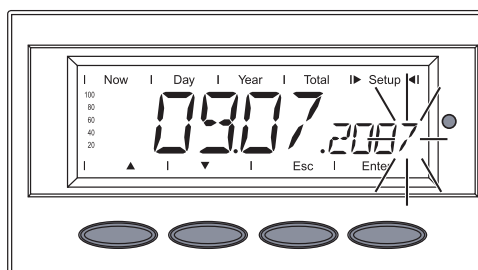

The fourth digit for the year flashes

17. Use the 'Up' and 'Down' keys to select a value for the fourth year digit
▲ ▼
18. Press the 'Enter' key

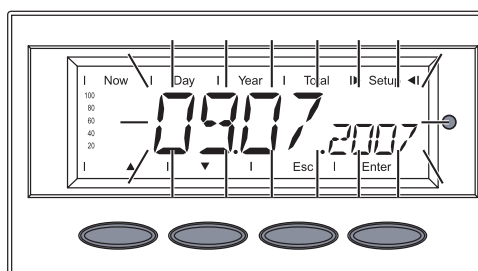

The set date then flashes:

19. Press the 'Enter' key

**Setting the
'TIME' Menu
Option**
(continued)

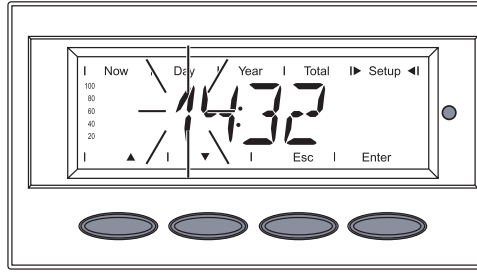

The **time** is displayed (HH:MM), the first digit for the hour flashes

20. Use the 'Up' and 'Down' keys to select a value for the first hour digit
▲ ▼

21. Press the 'Enter' key

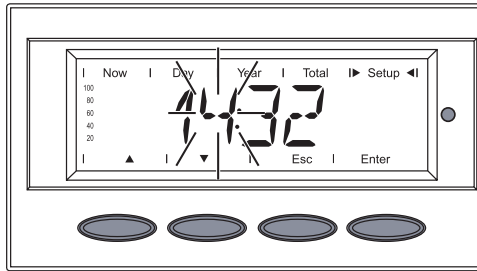

The second digit for the hour flashes

22. Use the 'Up' and 'Down' keys to select a value for the second hour digit
▲ ▼

23. Press the 'Enter' key

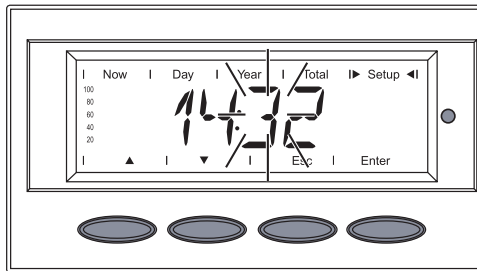

The first digit for the minutes flashes

24. Use the 'Up' and 'Down' keys to select a value for the first minutes digit
▲ ▼

25. Press the 'Enter' key

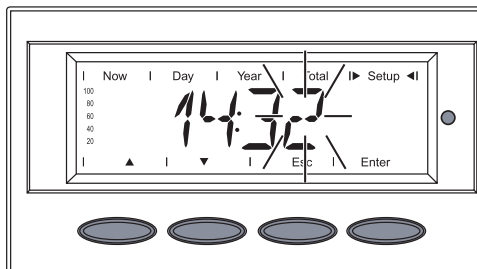

The second digit for the minutes flashes

26. Use the 'Up' and 'Down' keys to select a value for the second minutes digit
▲ ▼

27. Press the 'Enter' key

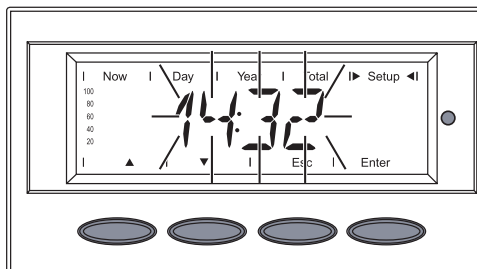

The set time will now flash

28. Press the 'Enter' key to apply the time
29. Press the 'Esc' key to exit the 'TIME' menu option

Displaying the 'STATE_{PS}' menu option

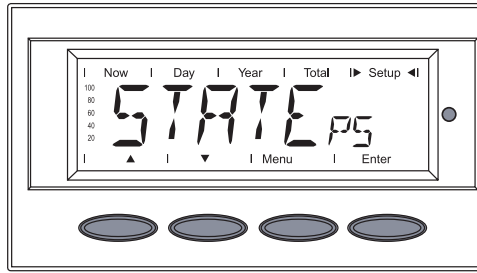

1. Select the 'STATE_{PS}' menu option
2. Press the 'Enter' key

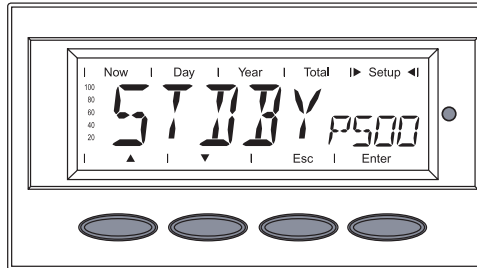

The status of the first power module PS00 will be displayed, e.g.: STDBY_{PS00}

STDBY = standby (no grid feed)

3. Press the 'Enter' key to display the last status message saved

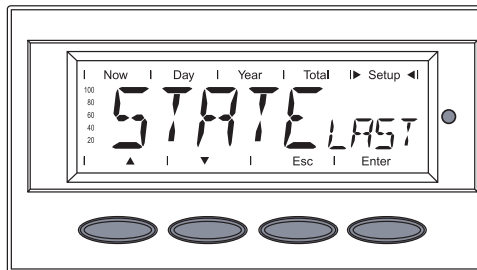

The display switches between ...

'STATE_{LAST}'

and

the last saved status message.

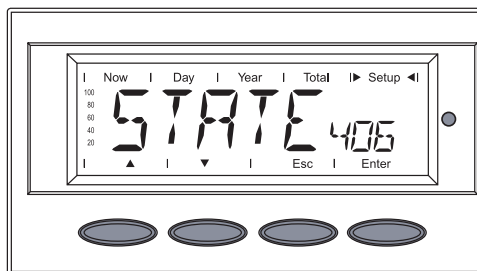

4. Press the 'Esc' key

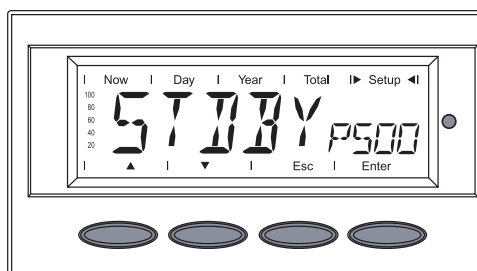

The status of the first power module PS00 will be displayed again

5. Use the 'Down' key to select the second or third power module PS01 or PS02

The status of the selected power module will be displayed, e.g.: RUN_{PS01}

RUN = active grid feed

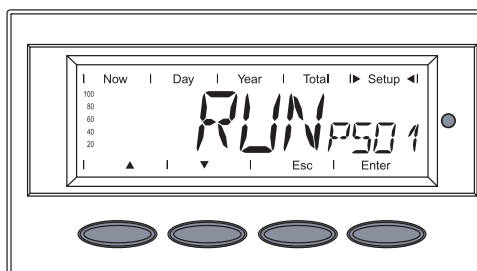

6. Press the 'Enter' key to display the last status message saved

**Displaying the
'STATEPs'
menu option**
(continued)

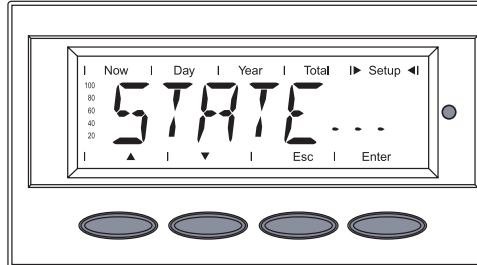
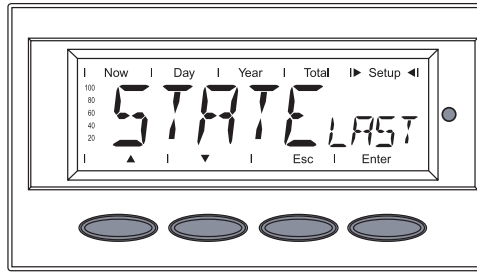

The display switches between
...
'STATELAST'

and

the last saved status message.

7. Press the 'Esc' key 2x to exit the 'STATEPs' menu option

**Displaying the
'VERSIon'
menu option**

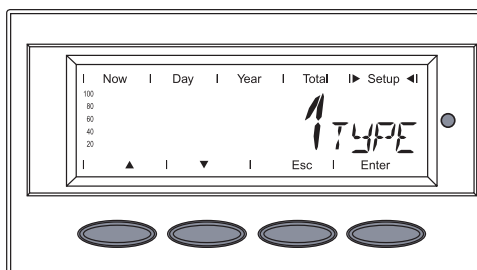
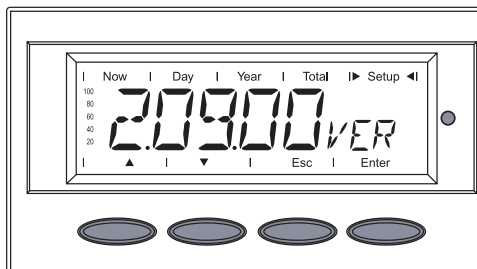
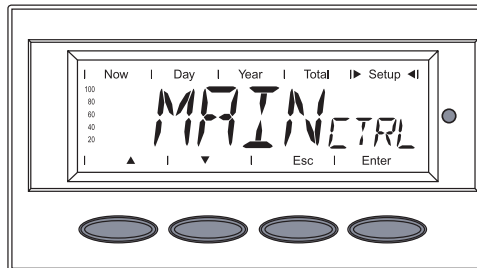
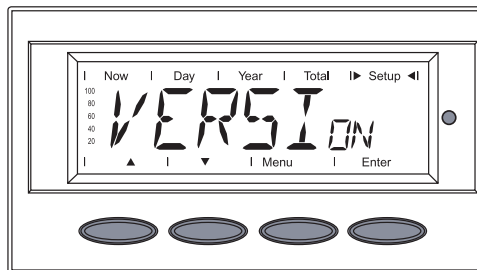

1. Select the 'VERSIon' menu option
2. Press the 'Enter' key

'MAINCTRL' is displayed

3. Press 'Enter' to display the version number of the IG Brain unit

The version number of the IG Brain unit is displayed

4. Press the 'Down' key to display the component ID.
▼

The component ID of the IG Brain unit is displayed

5. Press 'Down' to display the identification number of the IG Brain unit
▼

**Displaying the
'VERSION'
menu option**
(continued)

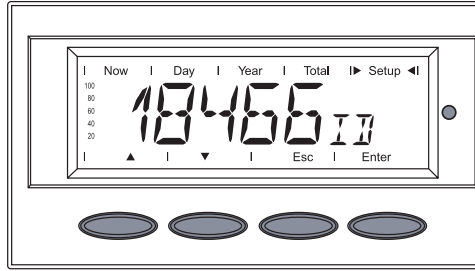

The identification number of the IG Brain unit is displayed

6. Press 'Down' to display the hardware version of the IG Brain unit
▼

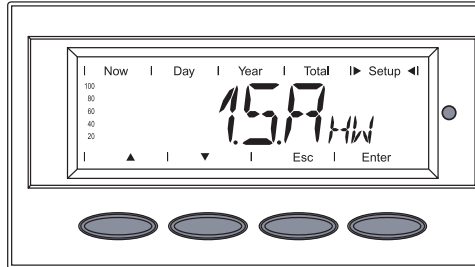

The hardware version of the IG Brain unit is displayed

7. Press the 'Esc' key

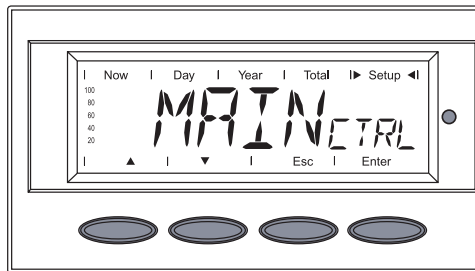

'MAINCTRL' is displayed

8. Press the 'Down' key to display the power modules
▼

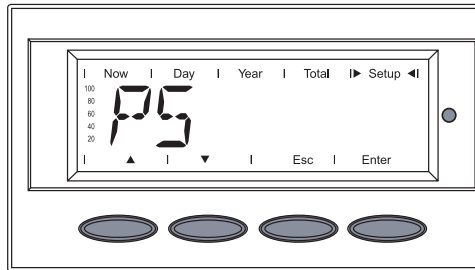

'PS' is displayed

9. Press the 'Enter' key

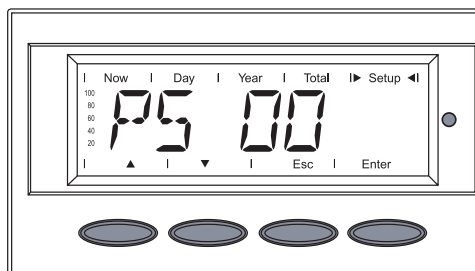

The first power module 'PS 00' is displayed

10. Select the desired power module using the 'Down' key
▼
11. Press the 'Enter' key

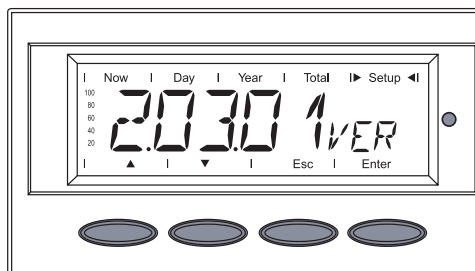

The version number of the selected power module is displayed

12. Press the 'Down' key to display the component ID
▼

**Displaying the
'VERSION'
menu option**
(continued)

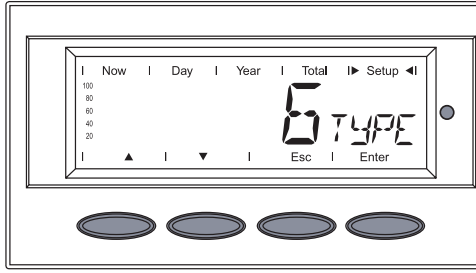

The component ID of the selected power module is displayed

13. Press the 'Down' key to display the power module identification number
▼

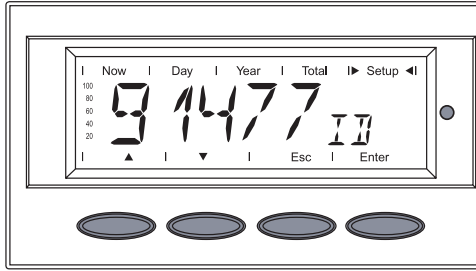

The identification number of the selected power module is displayed

14. Press 'Down' to display the hardware version of the power module
▼

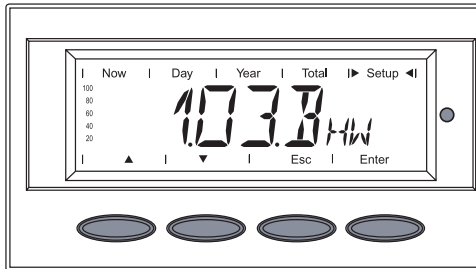

The hardware version of the selected power module is displayed

15. Press the 'Esc' key

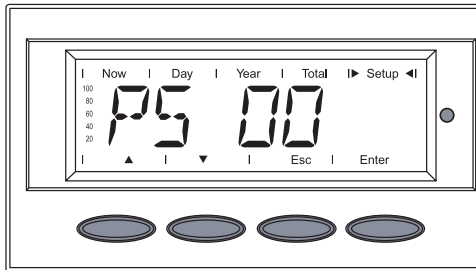

The selected power module is shown

16. Press the 'Esc' key

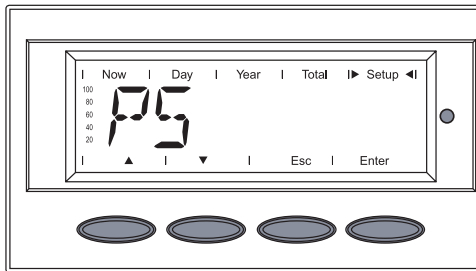

'PS' is displayed

17. Press the 'Esc' key to exit the 'VERSION' menu option

Installation and Startup

Fronius IG Plus Installation and Connection

Fronius IG Plus Setup

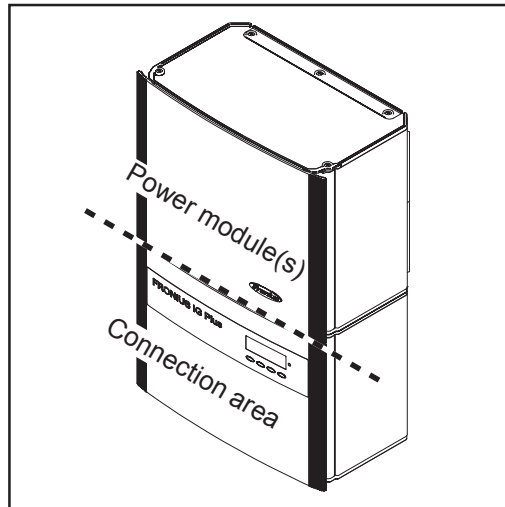

Connection area and power module on the Fronius IG Plus

Overview

'Fronius IG Plus Installation and Connection' contains the following sections:

- Fronius IG Plus Connection Options
- Target Punch-outs on the Fronius IG Plus
- Location Selection
- Fronius IG Plus Installation
- Connecting the Fronius IG Plus to the Public Grid (AC)
- Connecting Solar Module Strings to the Fronius IG Plus (DC)
- Closing Fronius IG Plus

Fronius IG Plus Connection Options

Fronius IG Plus Connection Options

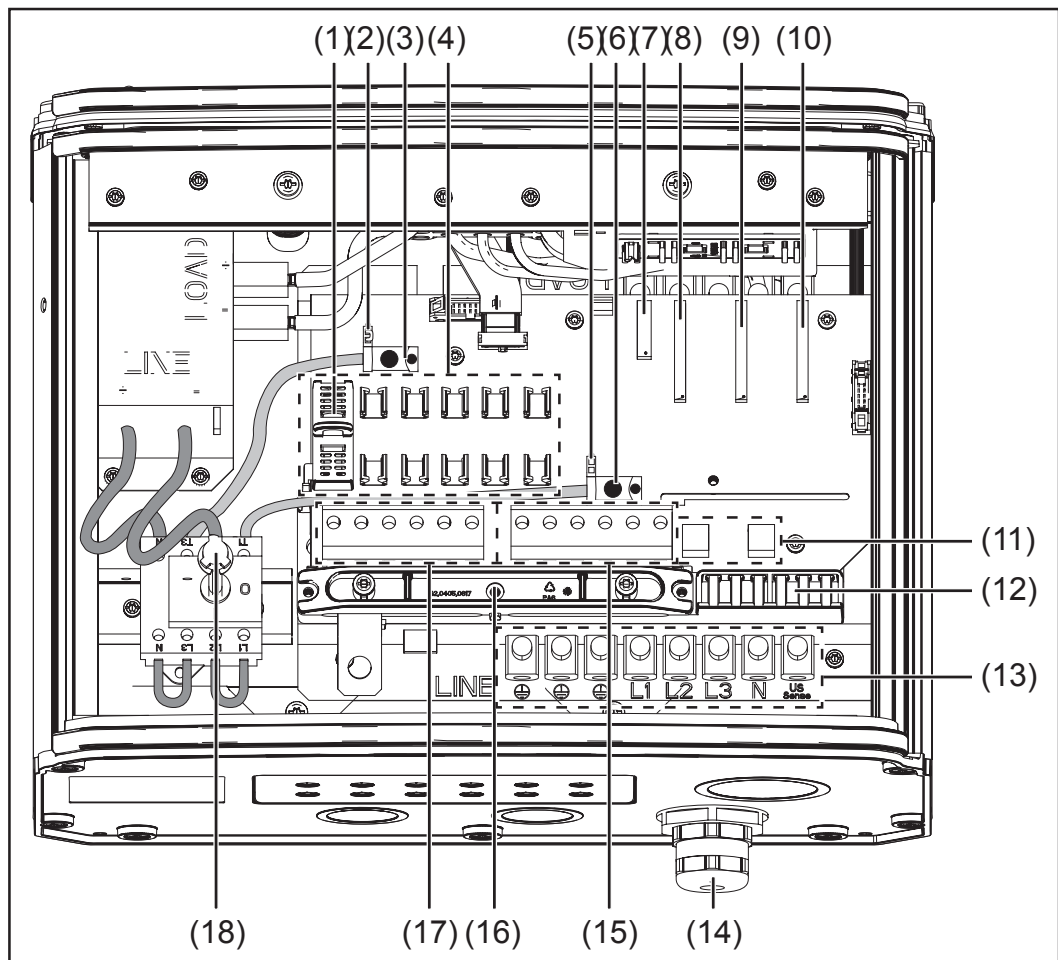

Connections on the Fronius IG Plus

Item	Description
(1)	Fuse cover (6 x for string fuses, 1 x for the solar module ground fuse)
(2)	Jumper slot SM _{ON}
(3)	DC- main switch cable
(4)	6 DC+ fuse holders
(5)	Jumper slot SM _{OFF}
(6)	DC- main switch cable
(7)	Plug-in card for country setup (IG Brain)
(8)	Open card slot for an option card
(9)	Open card slot for a second option card
(10)	Open card slot for a third option card
(11)	Fuse holder for the solar module ground
(12)	Strain relief device for plug-in card cable
(13)	AC-side terminals

**Fronius IG
Plus Connection Options**
(continued)

Item	Description
(14)	Metric screw joint M32 or M40 (AC connection)
(15)	6 DC- terminals
(16)	Strain relief device for solar module strings
(17)	6 DC+ terminals
(18)	DC main switch

Target Punch-outs on the Fronius IG Plus

General

The Fronius IG Plus contains several target punch-outs of different sizes. When punched out, the openings are used for the inputs of various cables.

Target Punch-outs for Cable Inputs

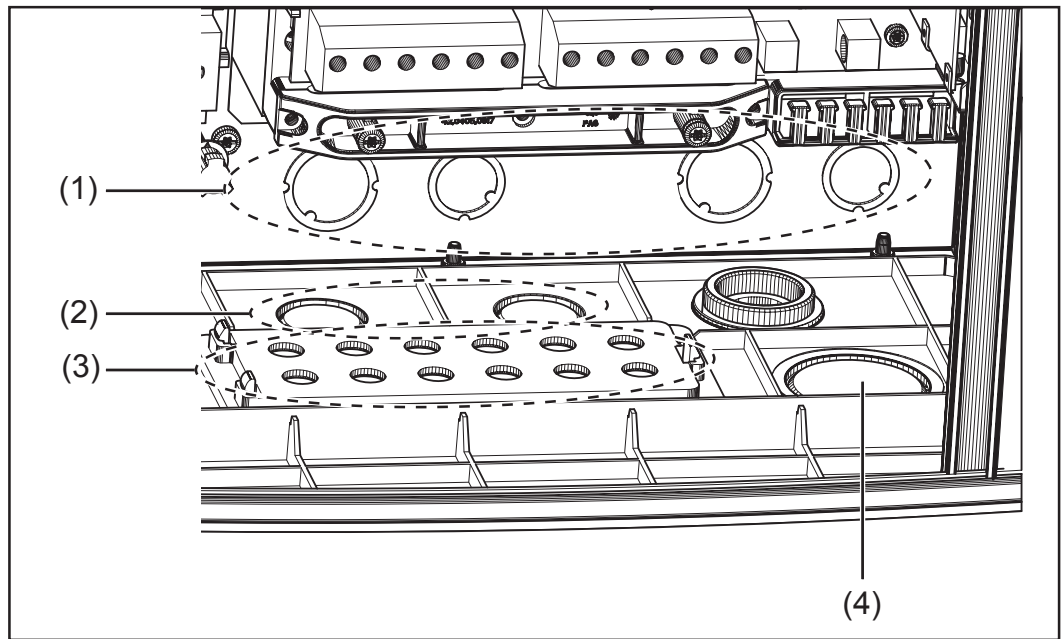

Target punch-outs on the back and inside base of the Fronius IG Plus

Item	Description
(1)	4 back cable inputs: Diameter 34.5 / 28 and 28 / 22.5 mm Cable openings that lead through the back to the inverter
	NOTE When using back cable inputs: - seal all open spaces at IP45 - use an edge guard to avoid damaging the cable
(2)	2 cable inputs for metric screw joint M32 (for DC cable with a cable cross section > 16 mm ²)
(3)	12 cable inputs for 6 solar module strings DC (for a cable diameter of 5 - 9.2 mm)
(4)	Cable input for plug-in card cable



**Target Punch-
outs for Cable
Inputs**
(continued)



NOTE

- The target punch-outs made from plastic as well as the larger ones made from metal should only be removed from the outside in.
- The smaller target punch-outs made from metal should be removed from the inside out.
- You should only remove the number of punch-outs required for the available cables (e.g. 6 openings for 3 module strings)

The plastic punch-outs are also equipped with center holes so that they can be drilled out if required.

Location Selection

General Location Selection

Please note the following criteria when selecting a location for the Fronius IG Plus:

It should only be installed on a stable, vertical wall

Max. ambient temperatures: -20 °C / +50 °C (-4 °F / +122.00 °F)

There should be a 20 cm (7.8 in) clearance on both sides of the Fronius IG Plus for the cool air vents.

Maintain a side distance of 30 cm (11.8 in) between individual Fronius IG Plus units.

The air flow direction within the inverter runs from right to left (cold air intake right, warm air exhaust left).

If the Fronius IG Plus is installed in a switch box (or similar enclosed area), then forced-air ventilation must be provided to ensure adequate heat dissipation.

The Fronius IG Plus is designed for installation both indoors and outdoors.

Location Selection for Inside Installation

Do not install the Fronius IG Plus near living areas because it may emit a small amount of noise under certain operating conditions.

Do not install the Fronius IG Plus in:

- Rooms with a large formation of dust
 - Rooms with a large formation of dust with conductive particles (e.g. iron filings)
 - Rooms with corrosive gases, acids or salts
 - Rooms where there is an increased risk of accidents, e.g. from farm animals (horses, cattle, sheep, pigs, etc.)
 - Stables or adjoining areas
 - Storage areas for hay, straw, chaff, animal feed, fertilizers, etc.
 - Storage or processing areas for fruit, vegetables or winegrowing products
 - Rooms used in the preparation of grain, green fodder or animal feeds
 - Greenhouses
-

Location Selection for Outside Installation

Because of its IP 44 protection class, the Fronius IG Plus is not susceptible to water spray from all directions

In order to protect the Fronius IG Plus display, it should not be exposed to direct sunlight. Ideally, the Fronius IG Plus should be installed in a protected location, e.g. near the solar modules or under a roof overhang.

Fronius IG Plus Installation

Attaching Wall Bracket

Important! Depending on the surface, different dowels and screws may be required for installing the wall bracket. These dowels and screws are not part of the scope of delivery for the Fronius IG Plus. The installer is responsible for selecting the proper dowels and screws.



NOTE The Fronius IG Plus should only be installed upright on the wall.

Only for Fronius IG Plus 120 / 150:

Because of logistical limits, the wall bracket for the Fronius IG Plus 120 and Fronius IG Plus 150 is divided into two parts.

- Assemble wall bracket as per work step 1

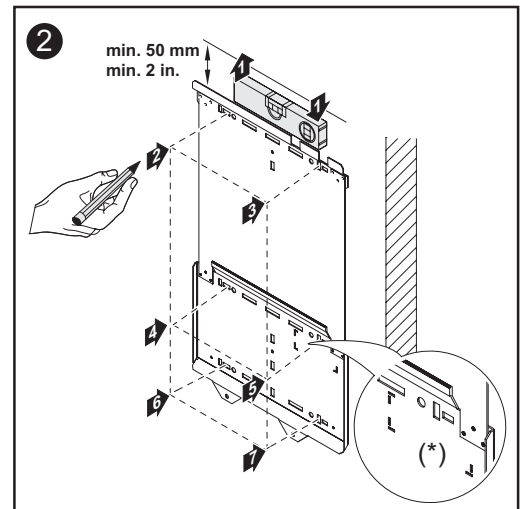
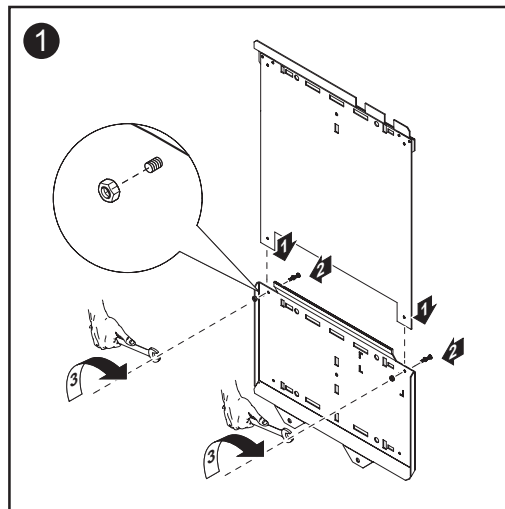

Important! When installing the wall bracket care should be taken to ensure that the display mark (*) on the wall bracket remains at eye level.

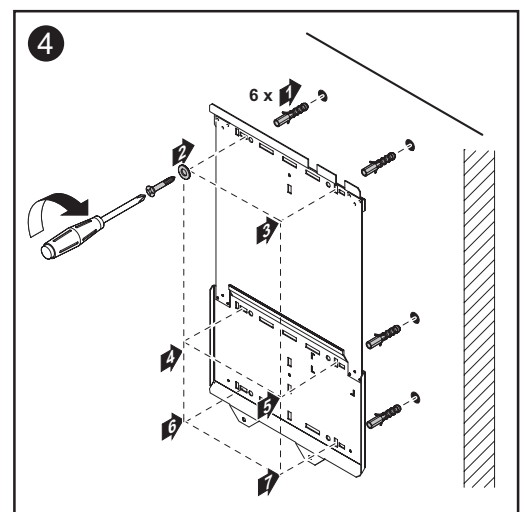
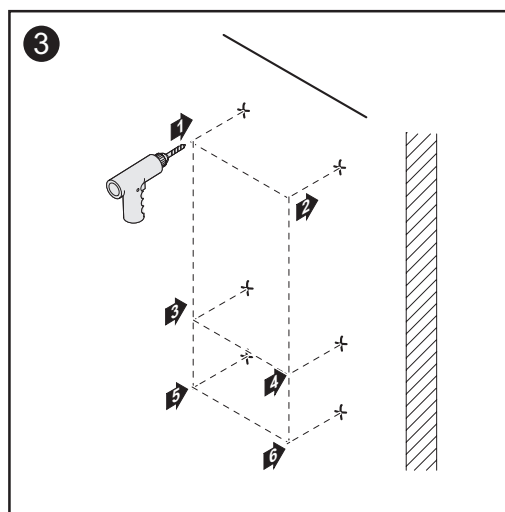

Fronius IG Plus Installation

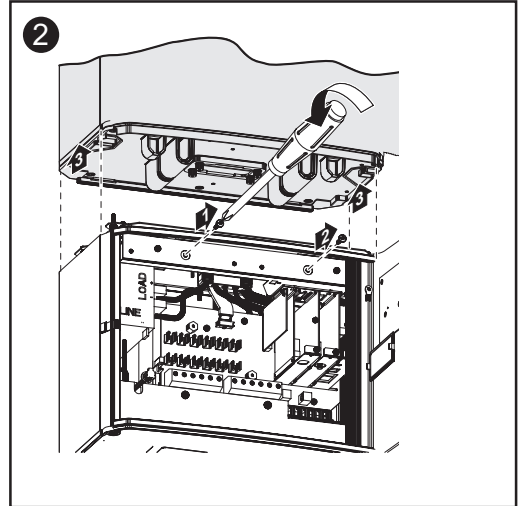
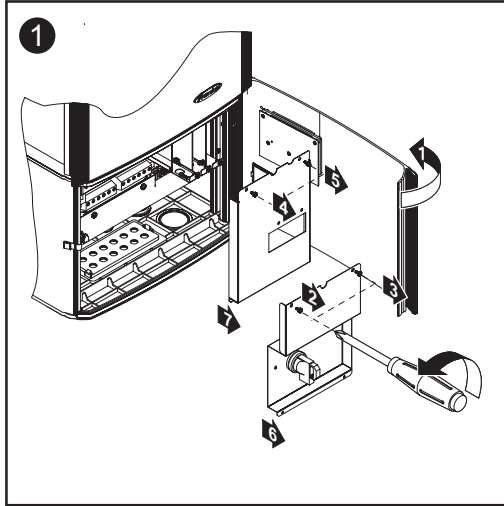

NOTE For Fronius IG Plus assembly, please ensure that:

- the wall bracket is fixed securely to the wall
- the connector is hung and fixed to the wall bracket
- the power module is hung on the wall bracket and fixed to the connector

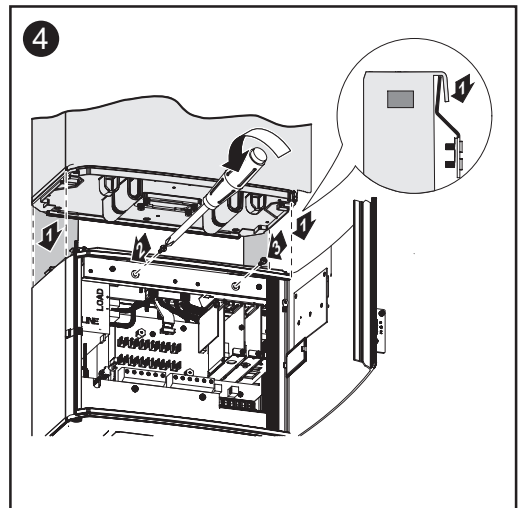
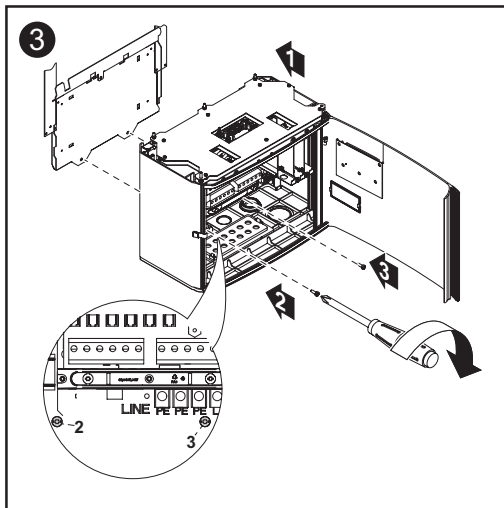

Connecting the Fronius IG Plus to the Public Grid (AC)

Monitoring the Mains Network

Important The resistance in the leads to the AC side connection terminals must be as low as possible for optimal functioning of mains network monitoring.

Installations with Several Inverters

For large photovoltaic systems, several Fronius IG Plus units can be connected in parallel. To ensure symmetrical feeding, connect the inverters uniformly to all 3 phases.

AC-side Terminals

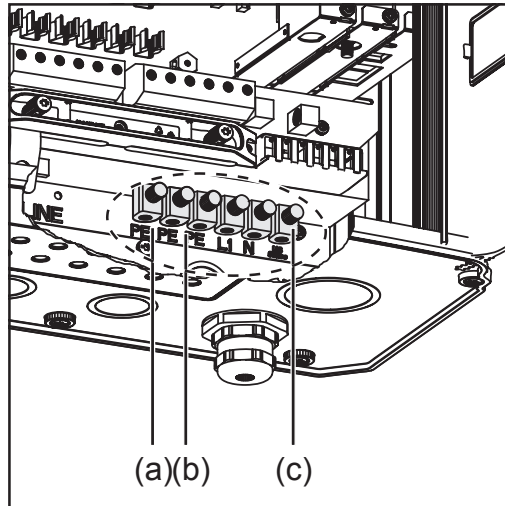

One-phase inverter

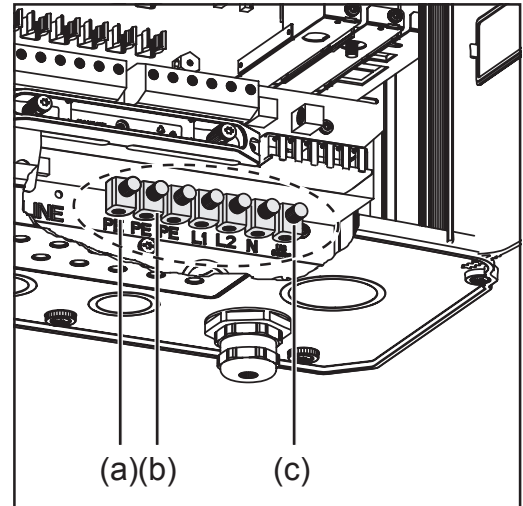

Two-phase inverter

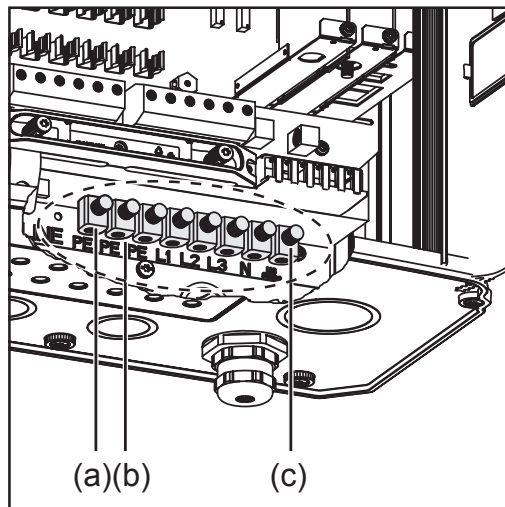

Three-phase inverter

Legend:

- L1 Phase conductor
- L2 Phase conductor
- L3 Phase conductor
- PE PE conductor
- N Neutral conductor
- (a) Terminal for grounding rod
- (b) Terminal for possible grounding of the solar module frame
- (c) 'US Sense' terminal (for USA)

max. cable cross section 25 mm²



NOTE Make sure that the network neutral conductor is grounded.

Cross Section of AC Cable

For metric screw joint M32:
Cable diameter 11 - 21 mm

For metric screw joint M40:
Cable diameter 19 - 28 mm

If required, use reducers for smaller cable diameters.

Connecting the Fronius IG Plus to the Public Grid (AC)

Only an authorized electrician is permitted to connect this equipment to the public grid.



WARNING! An electrical shock can be fatal. Danger from mains voltage and DC voltage from solar modules.

- The connection area should only be opened by a licensed electrician.
- The separate power module area should only be disconnected from the connection area after first being disconnected from the mains power.
- The separate power module area should only be opened by Fronius-trained service personnel.

Before making any connections, make sure that the AC and DC sides are disconnected from the inverter.

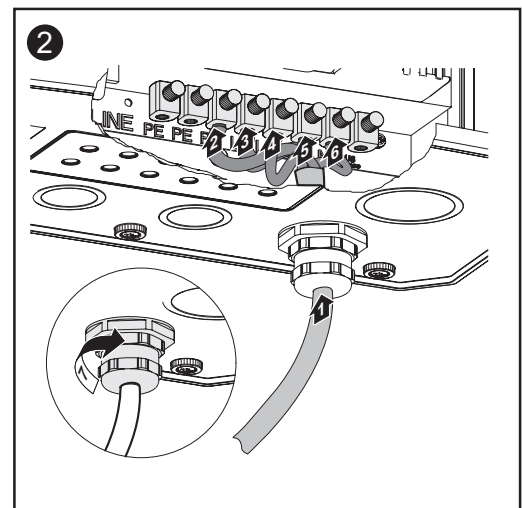
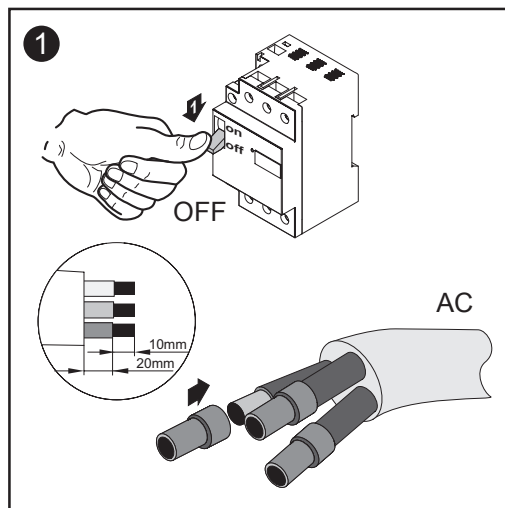

Fuse Recommendation for the AC-side

Inverter	Phases	Nominal capacity	Fuse protection
Fronius IG Plus 35 - 1	1	3.5 kW	1 x C 20 A
Fronius IG Plus 50 - 1	1	4 kW	1 x C 25 A
Fronius IG Plus 70 - 1	1	6.5 kW	1 x C 40 A
Fronius IG Plus 70 - 2	2	6.5 kW	2 x C 20 A
Fronius IG Plus 100 - 1	1	8 kW	1 x C 50 A
Fronius IG Plus 100 - 2	2	8 kW	2 x C 25 A
Fronius IG Plus 120 - 3	3	10 kW	3 x C 20 A
Fronius IG Plus 150 - 3	3	12 kW	3 x C 25 A

Connecting Solar Module Strings to the Fronius IG Plus (DC)

General Information About Solar Modules

In order to select suitable solar modules and get the most efficient use out of the Fronius IG Plus, please note the following points:

- If insolation is constant and the temperature is falling, the open-circuit voltage of the solar modules will increase. Open-circuit voltage may not exceed 600 V.
Open-circuit voltage over 600 V will damage the Fronius IG Plus voiding the warranty.
- More exact values for dimensioning solar modules for the chosen installation location can be provided using suitable calculation programs like the Fronius Solar.configurator (available at www.fronius.com).



NOTE Before connecting solar modules:

- make sure that the voltage specified by the manufacturer corresponds to the actual measured voltage
- determine whether or not a solar module ground is required

Safety



WARNING! An electrical shock can be fatal. Danger from mains voltage and DC voltage from solar modules.

- The connection area should only be opened by a licensed electrician.
- The separate power module area should only be disconnected from the connection area after first being disconnected from the mains power.
- The separate power module area should only be opened by Fronius-trained service personnel.

Before making any connections, make sure that the AC and DC sides are disconnected from the inverter.

The DC main switch is only used to switch off power to the power module. When the DC main switch is turned off, the connection area is still energized.

DC-Terminals

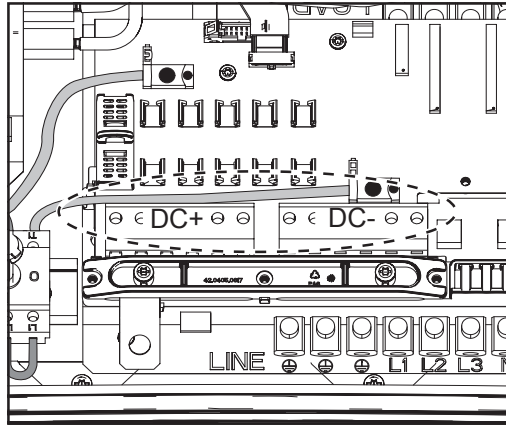

DC+ and DC- terminals on the Fronius IG Plus

Overview

'Connecting Solar Module Strings to the Fronius IG Plus (DC)' includes the following sections:

- Ungrounded System: Connecting Solar Module Strings
- Criteria for the Proper Selection of String Fuses
- Ungrounded System: Connecting Solar Module Strings with a Cable Cross Section $> 16 \text{ mm}^2$

- Solar Module Ground at Negative Pole: Connecting Solar Module Strings
- Criteria for the Proper Selection of String Fuses
- Solar Module Ground at Negative Pole: Connecting Solar Module Strings with a Cable Cross Section $> 16 \text{ mm}^2$
- Solar Module Ground at Negative Pole for Fronius IG Plus

- Solar Module Ground at Positive Pole: Connecting Solar Module Strings
- Criteria for the Proper Selection of String Fuses
- Solar Module Ground at Positive Pole: Connecting Solar Module Strings with a Cable Cross Section $> 16 \text{ mm}^2$
- Solar Module Ground at Negative Pole for Fronius IG Plus

Ungrounded System: Connecting Solar Module Strings

Cable Cross Section of Solar Module Strings

The cable cross section for solar module strings should be a maximum of 16 mm² per cable.

Ungrounded System: Connecting Solar Module Strings

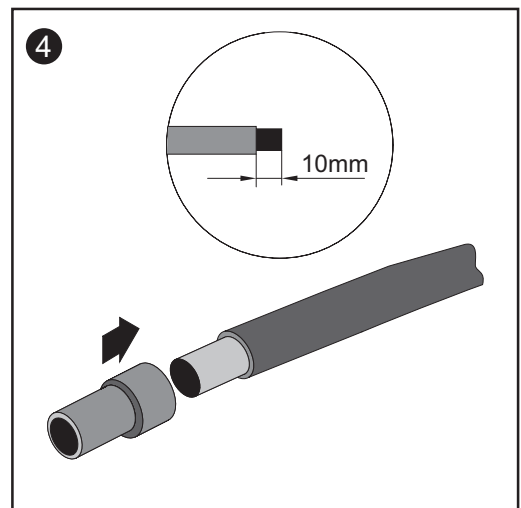
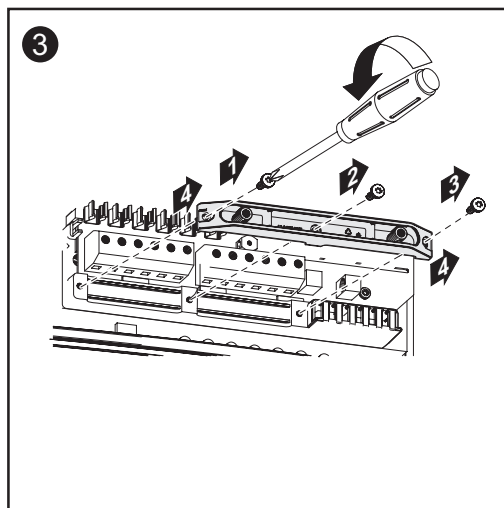
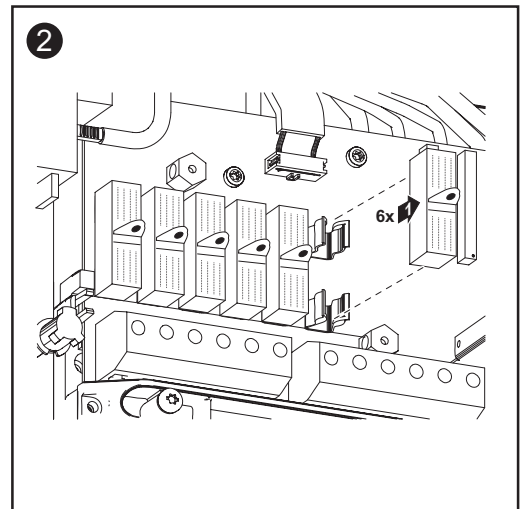
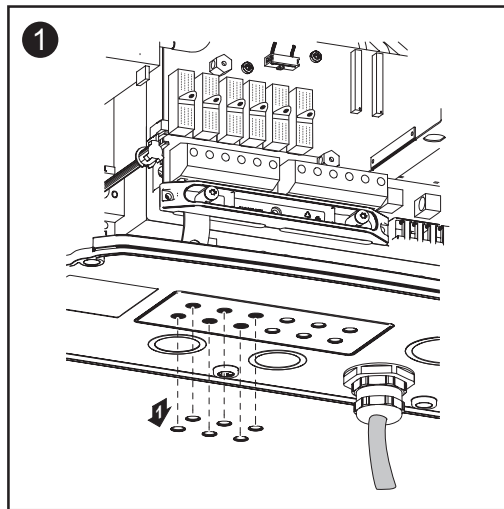

Ungrounded System: Connecting Solar Module Strings
(continued)

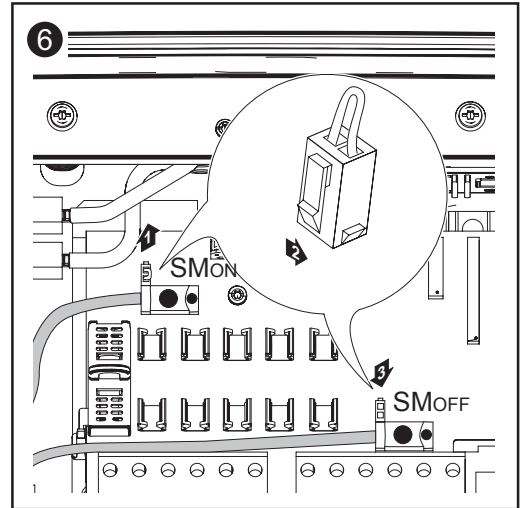
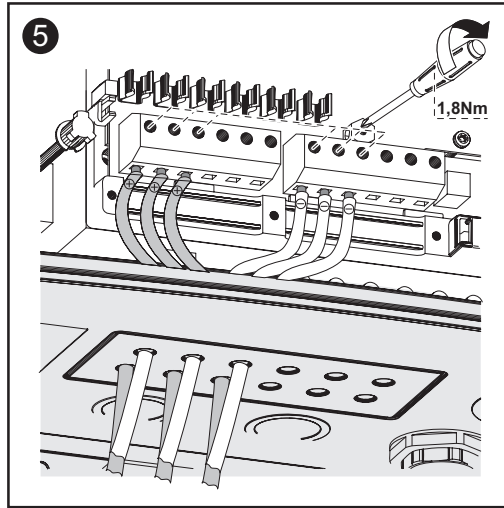

Important !

- Set the jumper from the 'SMON' position to the 'SMOFF' position for correct measurement results
- Check the polarity and voltage of the solar module strings: the voltage should be a max. of 600 V, the difference between the individual solar module strings should be a max. of 10 V.

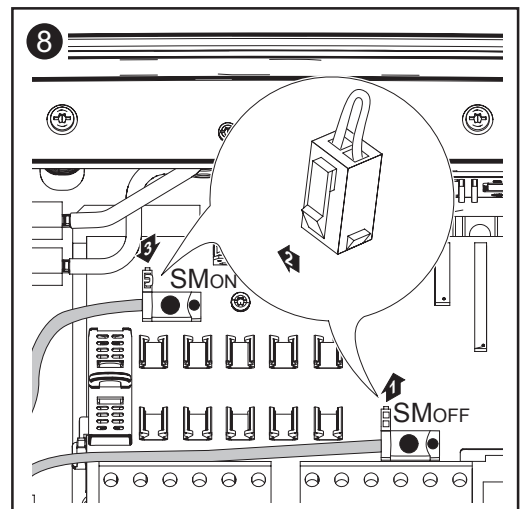
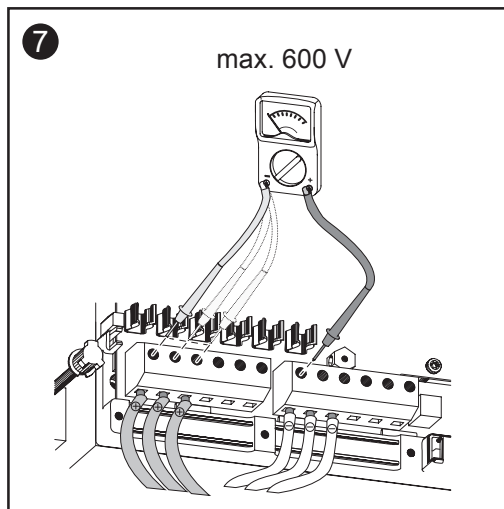

Important

- When connecting solar module strings, you should use metal bolts or string fuses with fuse covers in the fuse holder depending on the solar module manufacturer instructions. The metal bolts are included in the Fronius IG Plus scope of delivery.
- Place metal bolts with fuse covers in the fuse holders for unoccupied DC+ terminals.

Ungrounded System: Connecting Solar Module Strings
(continued)

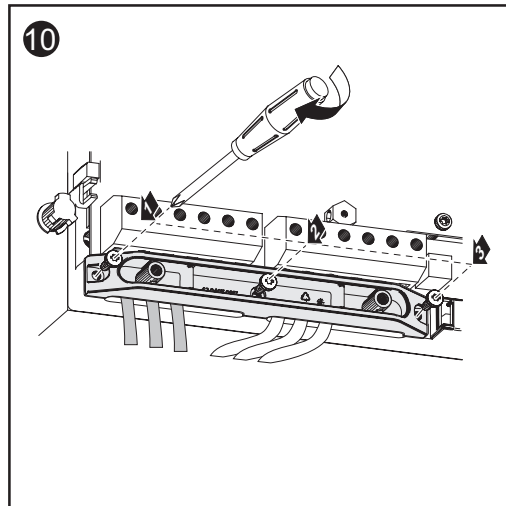
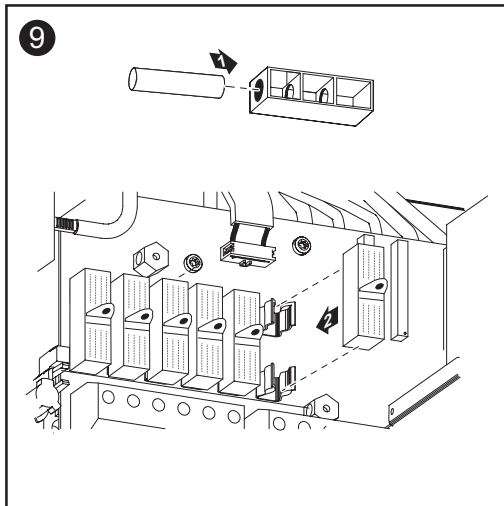

For more information about string fuses, please see 'Criteria for the Proper Selection of String Fuses.'

Selecting String Fuses

If the solar module manufacturer requires the use of string fuses for operation:

- Select string fuses according to the information from the solar module manufacturer or as per 'Criteria for the Proper Selection of String Fuses' (max. 20 A per solar module string, max. 6 solar module strings)

Important

- Please follow solar module safety instructions
- Please follow all solar module manufacturer requirements

Using String Fuses in Fronius IG Plus



NOTE If the solar module manufacturer requires the use of string fuses:

- Insert fuses with a fuse cover in the respective fuse holder
- Do not operate the Fronius IG Plus without fuse covers

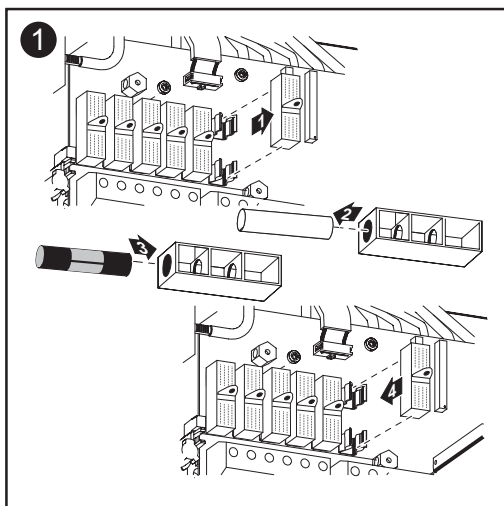

WARNING! An electrical shock can be fatal. Danger from DC voltage from solar modules. Fuse covers are for installation purposes only. They offer no protection against contact.

Criteria for the Proper Selection of String Fuses

General

The use of string fuses in the inverter also adds fuse protection to the solar modules.

A crucial factor for the fuse protection of solar modules is the maximum short circuit current (I_{SC} or STC) of the respective solar module.

Criteria for the Proper Selection of String Fuses

The following criteria must be fulfilled for each solar module string when using fuse protection:

- $I_N > 1.5 \times I_{SC}$
- $I_N < 2.00 \times I_{SC}$
- $U_N \geq 600 \text{ V DC}$
- Fuse dimensions: Diameter 10.3 x 35 - 38 mm

I_N Nominal current rating of fuse

I_{SC} also STC, short circuit current for standard test conditions according to solar module datasheet

U_N Nominal voltage rating of fuse

Effects of using underrated fuses

In case of underrated fuses, the nominal current value is less than the short circuit current of the solar module.

Effect:

The fuse may trip in intensive lighting conditions.

Fuse Recommendations - Application Example



NOTE Only select fuses suitable for a voltage of 600 V DC.

e.g.: Maximum short circuit current (I_{SC}) of the solar module = 5.75 A

According to the criteria for selecting the correct fuse, the fuse must have a nominal current greater than 1.5 times the short circuit current:

$$5.75 \text{ A} \times 1.5 = 8.625 \text{ A}$$

The fuse that should be selected according to the 'Fuses' table: KLK D 9 with 9.0 A and 600 V AC / DC

Fuses

Nominal current value	Fuse	Nominal current value	Fuse
1.0 A	KLK D 1	6.0 A	KLK D 6
1.5 A	KLK D 1 $\frac{1}{2}$	7.0 A	KLK D 7
2.0 A	KLK D 2	8.0 A	KLK D 8
2.5 A	KLK D 2 $\frac{1}{2}$	9.0 A	KLK D 9
3.0 A	KLK D 3	10.0 A	KLK D 10
3.5 A	KLK D 3 $\frac{1}{2}$	12.0 A	KLK D 12
4.0 A	KLK D 4	15.0 A	KLK D 15
5.0 A	KLK D 5	20.0 A	KLK D 20

'Fuses' table: Excerpt of suitable fuses, e.g. Littelfuse fuses

Ungrounded System: Connecting Solar Module Strings with a Cable Cross Section > 16 mm²

General

As an option, you can also connect DC cables to the Fronius IG Plus with a cross section > 16 mm², e.g. when the DC cables from the solar modules are combined outside of the inverter leads into a large string.

Additional Required Components

The following additional components are required for connecting DC cables with a cross section > 16 mm²:

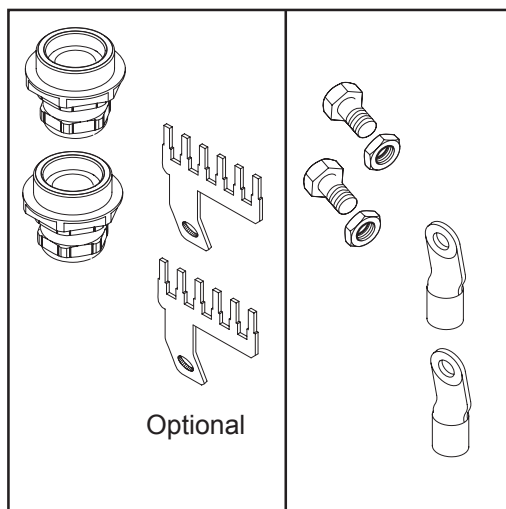

Additional Required Components

- 2 metric screw joints M32 (degree of protection min. IP45)
 - 2 connection distributors (copper plate)
- metric screw joints and connection distributors are available from Fronius as an option
- 2 cable lugs for the DC cables
- select cable lugs that match the available DC cables
- 2 M10 screws
 - 2 M10 hexagon nuts

Ungrounded System: Connecting Solar Module Strings with a Cable Cross Section > 16 mm²

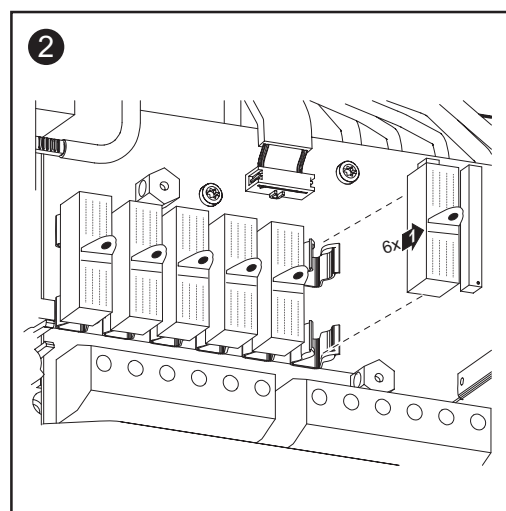
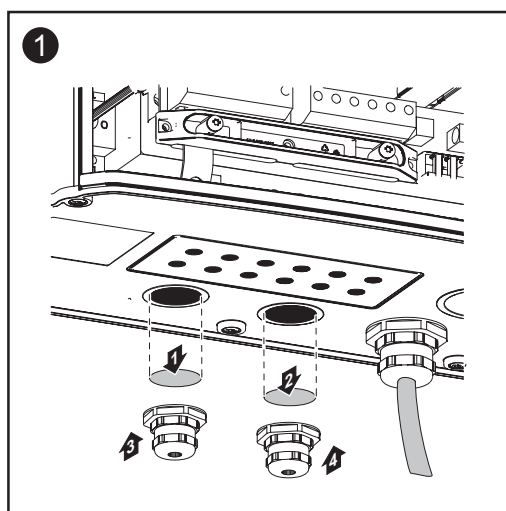

Ungrounded System: Connecting Solar Module Strings with a Cable Cross Section > 16 mm²
 (continued)

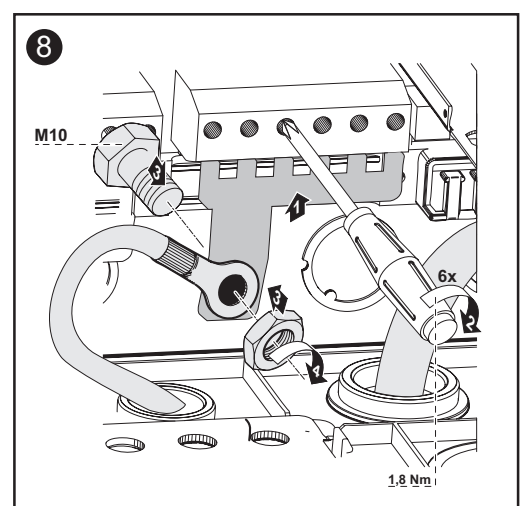
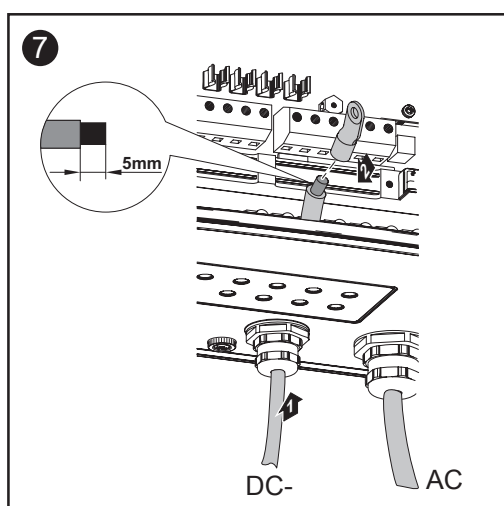
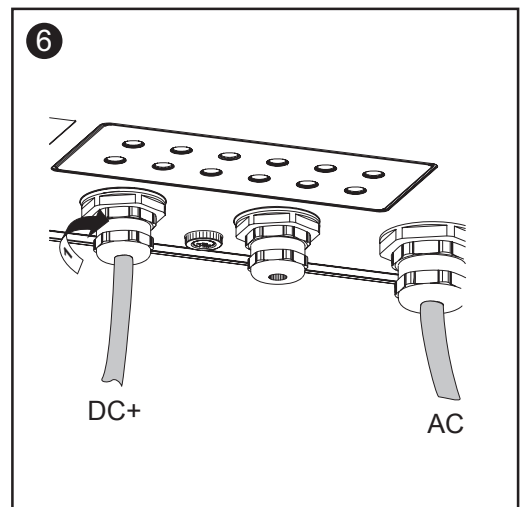
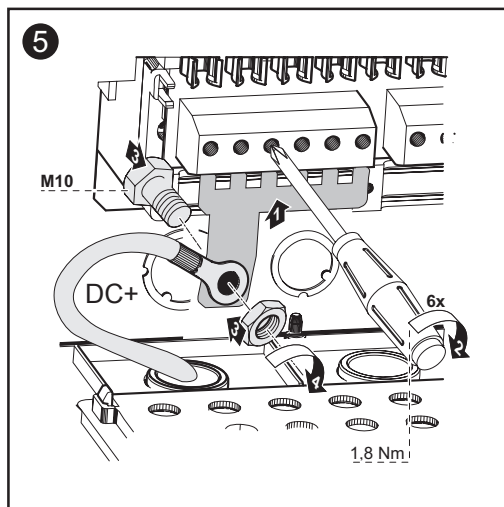
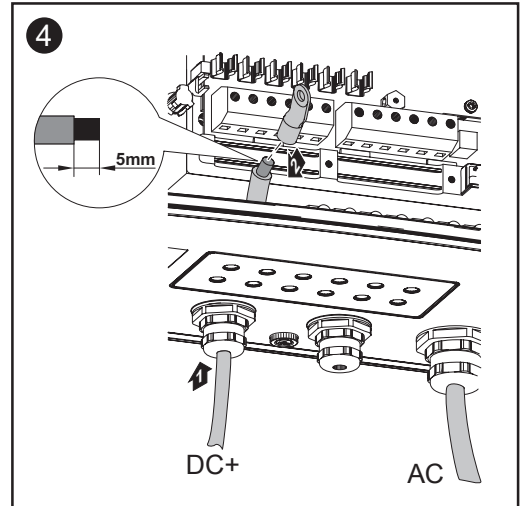
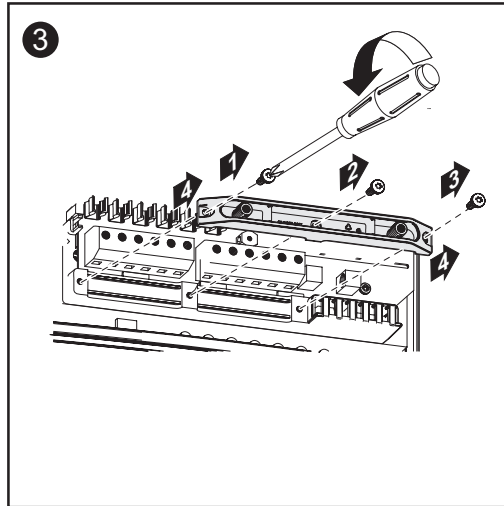

Ungrounded System: Connecting Solar Module Strings with a Cable Cross Section > 16 mm²
(continued)

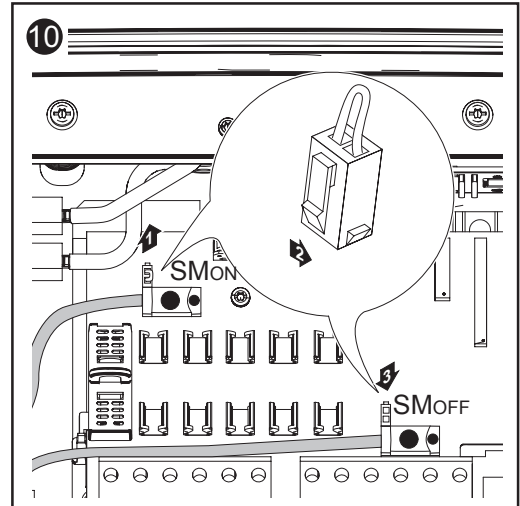
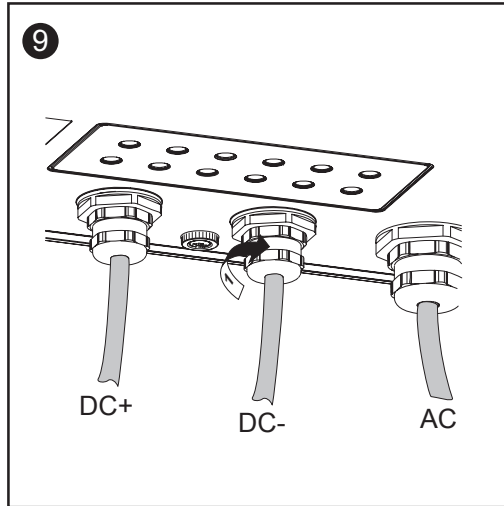

Important

- Set the jumper from the 'SMON' position to the 'SMOFF' position for correct measurement results
- Check the polarity and voltage of the DC cable: the voltage should be a max. of 600 V.

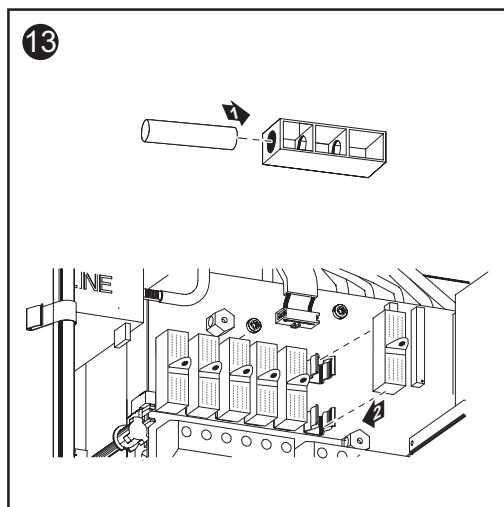
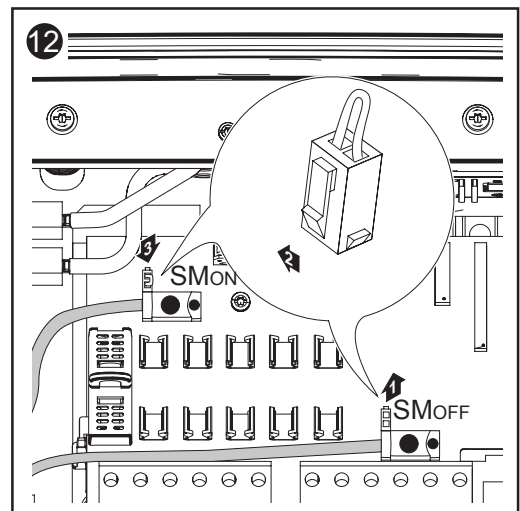
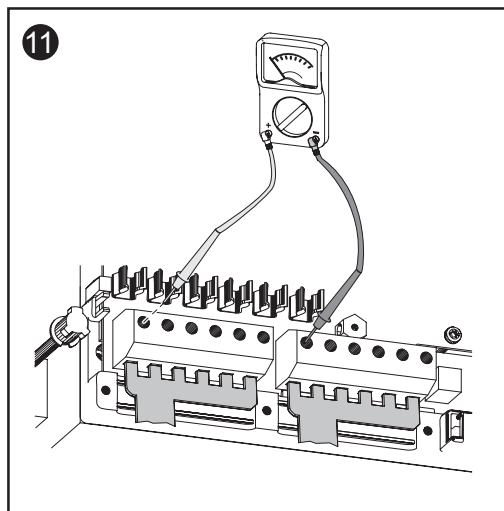

Important When using connection distributors (copper plate), insert 6 metal bolts with fuse covers in the fuse holder. The metal bolts are included in the Fronius IG Plus scope of delivery.

Solar Module Ground at Negative Pole: Connecting Solar Module Strings

General

The following working steps are only necessary when the solar module manufacturer requires a solar module ground at the negative pole.

Cable Cross Section of Solar Module Strings

The cable cross section for solar module strings should be a maximum of 16 mm² per cable.

Solar Module Ground at Negative Pole: Connecting Solar Module Strings

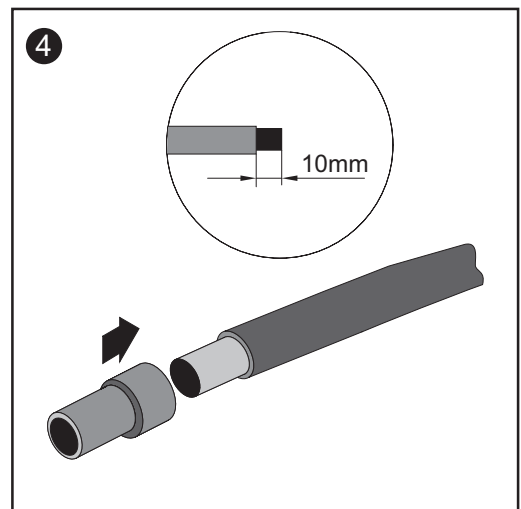
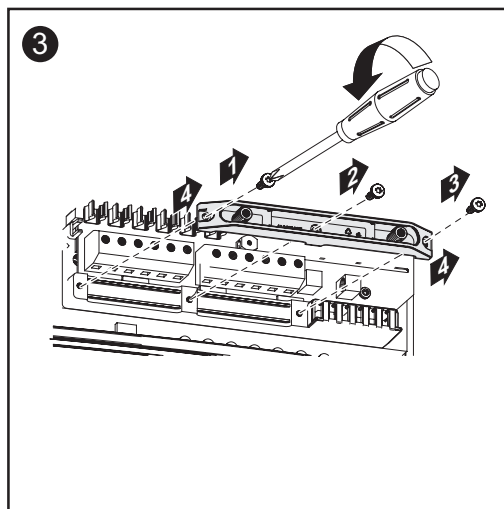
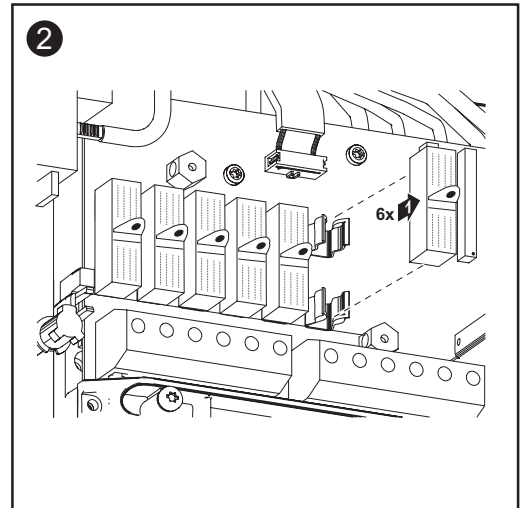
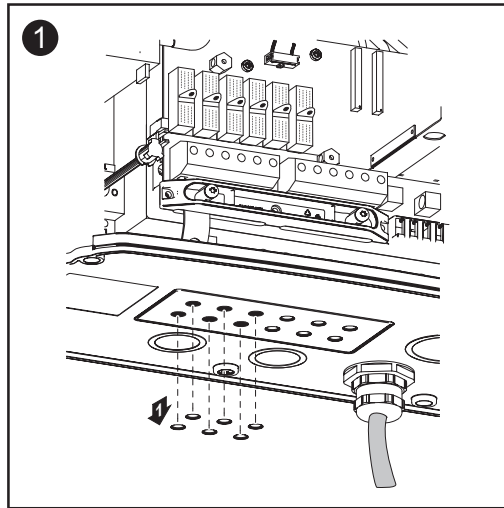

Solar Module Ground at Negative Pole: Connecting Solar Module Strings
(continued)

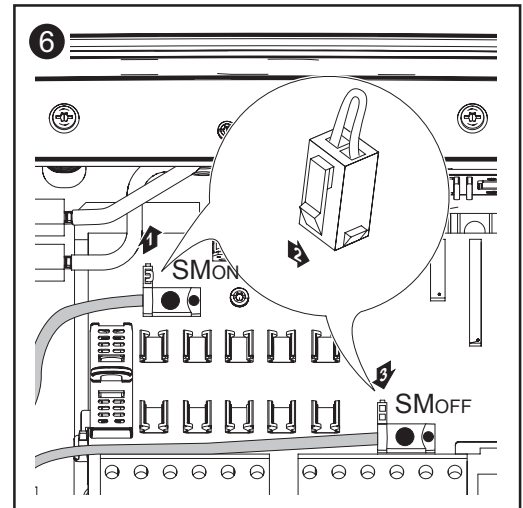
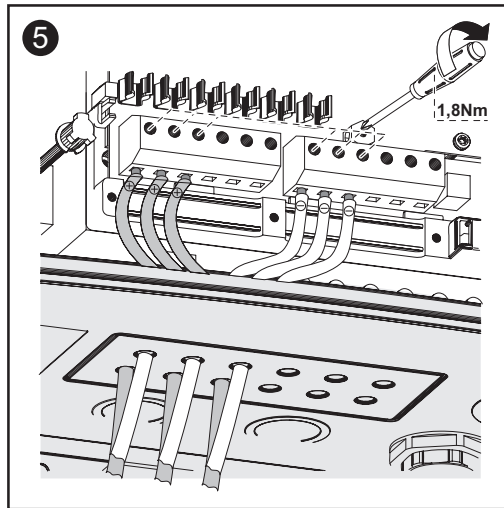

Important

- Set the jumper from the 'SMON' position to the 'SMOFF' position for correct measurement results
- Check the polarity and voltage of the solar module strings: the voltage should be a max. of 600 V, the difference between the individual solar module strings should be a max. of 10 V.

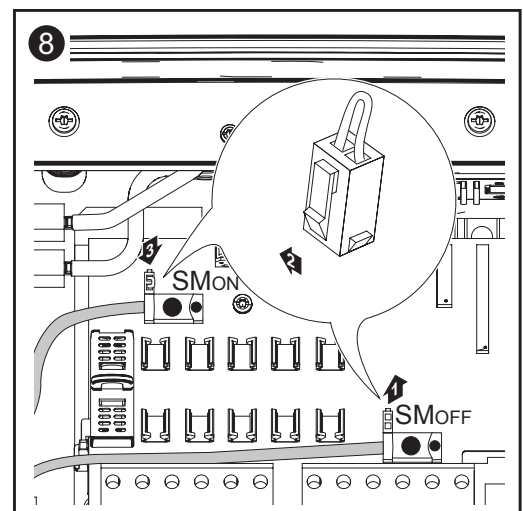
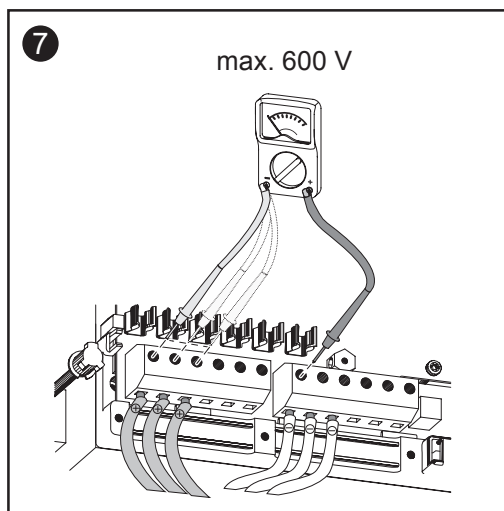

Important

- When connecting solar module strings, you should use metal bolts or string fuses with fuse covers in the fuse holder depending on the solar module manufacturer instructions. The metal bolts are included in the Fronius IG Plus scope of delivery.
- Place metal bolts with fuse covers in the fuse holders for unoccupied DC+ terminals.

Solar Module Ground at Negative Pole: Connecting Solar Module Strings
(continued)

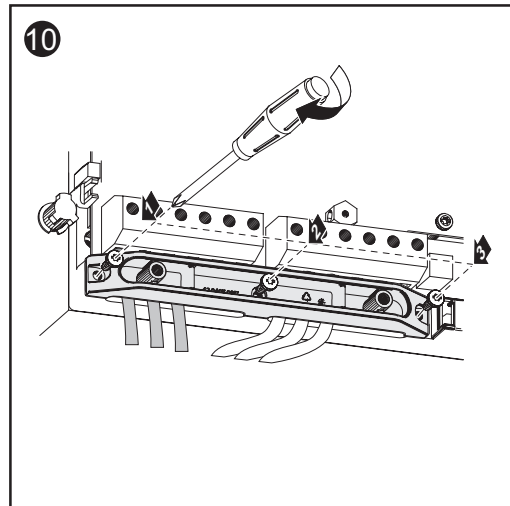
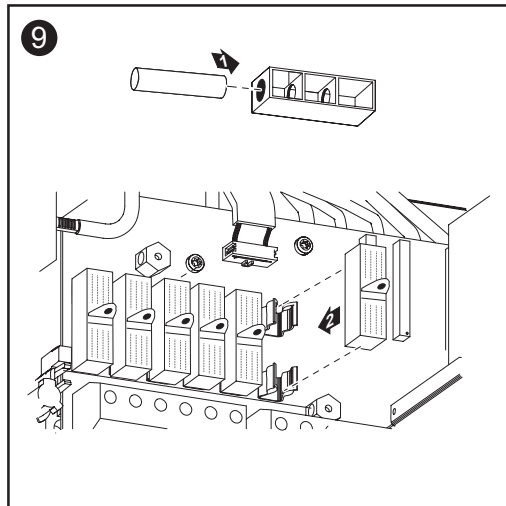

For more information about string fuses, please see 'Criteria for the Proper Selection of String Fuses.'

Selecting String Fuses

If the solar module manufacturer requires the use of string fuses for operation:

- Select string fuses according to the information from the solar module manufacturer or as per 'Criteria for the Proper Selection of String Fuses' (max. 20 A per solar module string, max. 6 solar module strings)

Important

- Please follow solar module safety instructions
- Please follow all solar module manufacturer requirements

Using String Fuses in Fronius IG Plus



NOTE If the solar module manufacturer requires the use of string fuses:

- Insert fuses with a fuse cover in the respective fuse holder
- Do not operate the Fronius IG Plus without fuse covers

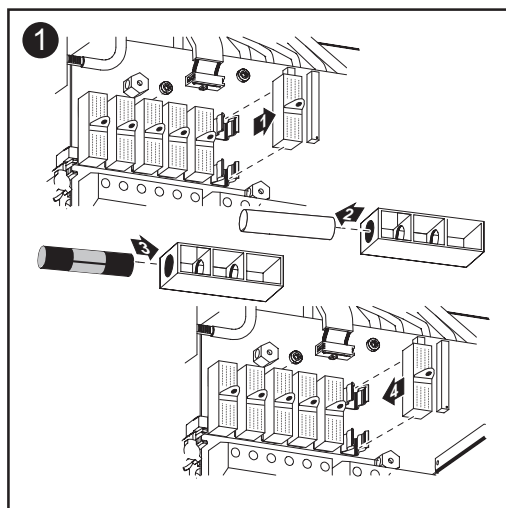

WARNING! An electrical shock can be fatal. Danger from DC voltage from solar modules. Fuse covers are for installation purposes only. They offer no protection against contact.

Criteria for the Proper Selection of String Fuses

General

The use of string fuses in the inverter also adds fuse protection to the solar modules.

A crucial factor for the fuse protection of solar modules is the maximum short circuit current (I_{SC} or STC) of the respective solar module.

Criteria for the Proper Selection of String Fuses

The following criteria must be fulfilled for each solar module string when using fuse protection:

- $I_N > 1.5 \times I_{SC}$
- $I_N < 2.00 \times I_{SC}$
- $U_N \geq 600 \text{ V DC}$
- Fuse dimensions: Diameter 10.3 x 35 - 38 mm

I_N Nominal current rating of fuse

I_{SC} also STC, short circuit current for standard test conditions according to solar module datasheet

U_N Nominal voltage rating of fuse

Effects of using underrated fuses

In underrated fuses, the nominal current value is less than the short circuit current of the solar module.

Effect:

The fuse may trip in intensive lighting conditions.

Fuse Recommendations - Application Example



NOTE Only select fuses suitable for a voltage of 600 V DC.

e.g.: Maximum short circuit current (I_{SC}) of the solar module = 5.75 A

According to the criteria for selecting the correct fuse, the fuse must have a nominal current greater than 1.5 times the short circuit current:

$$5.75 \text{ A} \times 1.5 = 8.625 \text{ A}$$

The fuse that should be selected according to the 'Fuses' table: KLK D 9 with 9.0 A and 600 V AC / DC

Fuses

Nominal current value	Fuse	Nominal current value	Fuse
1.0 A	KLK D 1	6.0 A	KLK D 6
1.5 A	KLK D 1 $\frac{1}{2}$	7.0 A	KLK D 7
2.0 A	KLK D 2	8.0 A	KLK D 8
2.5 A	KLK D 2 $\frac{1}{2}$	9.0 A	KLK D 9
3.0 A	KLK D 3	10.0 A	KLK D 10
3.5 A	KLK D 3 $\frac{1}{2}$	12.0 A	KLK D 12
4.0 A	KLK D 4	15.0 A	KLK D 15
5.0 A	KLK D 5	20.0 A	KLK D 20

'Fuses' table: Excerpt of suitable fuses, e.g. Littelfuse fuses

Solar Module Ground at Negative Pole: Connecting Solar Module Strings with a Cable Cross Section > 16 mm²

General

The following working steps are only necessary when the solar module manufacturer requires a solar module ground at the negative pole.

As an option, you can also connect DC cables to the Fronius IG Plus with a cross section > 16 mm², e.g. when the DC cables from the solar modules are combined outside of the inverter leads into a large string.

Additional Required Components

The following additional components are required for connecting DC cables with a cross section > 16 mm²:

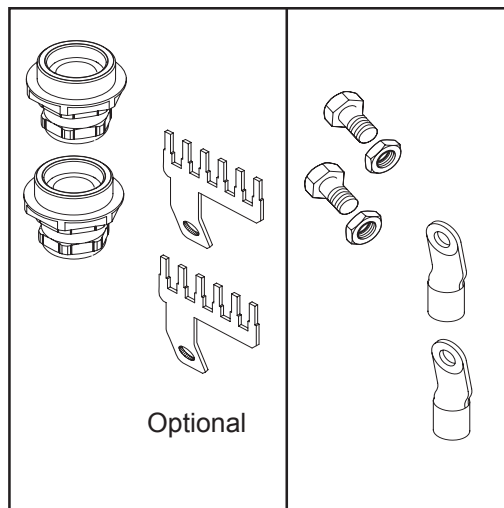

Additional Required Components

- 2 metric screw joints M32 (degree of protection min. IP45)
- 2 connection distributors

- metric screw joints and connection distributors are available from Fronius as an option

- 2 cable lugs for the DC cables

- select cable lugs that match the available DC cables

- 2 M10 screws
- 2 M10 hexagon nuts

Solar Module Ground at Negative Pole: Connecting Solar Module Strings with a Cable Cross Section > 16 mm²

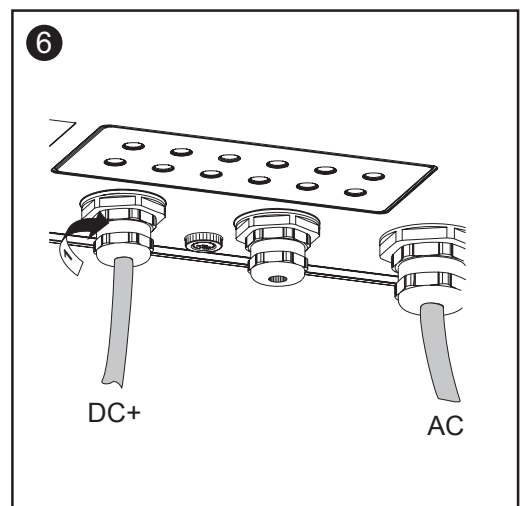
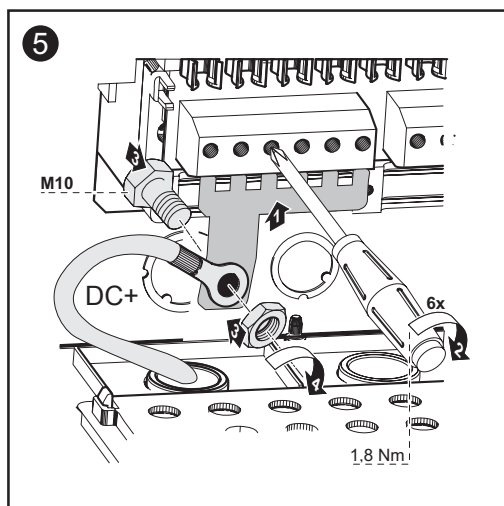
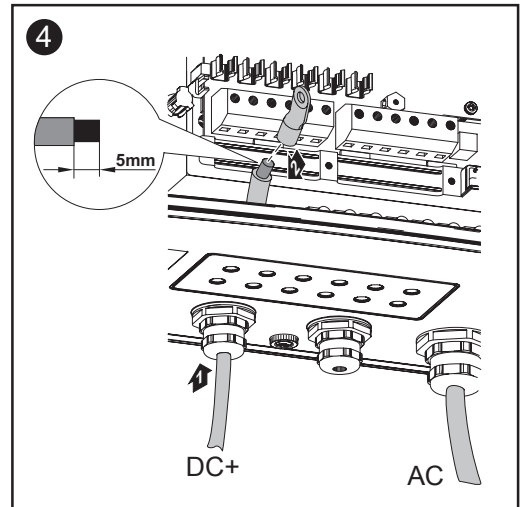
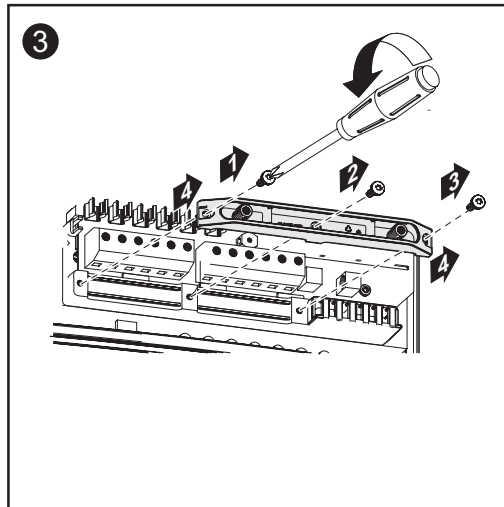
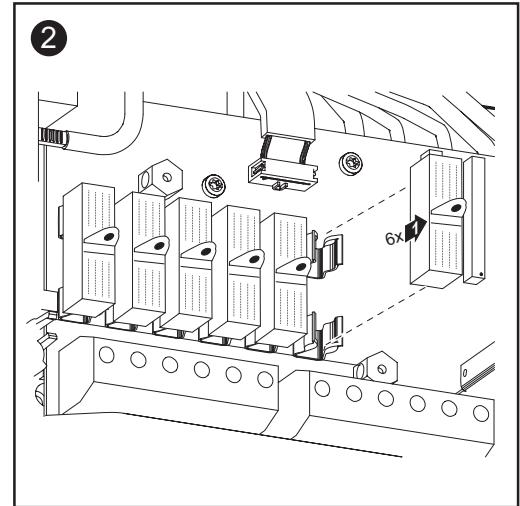
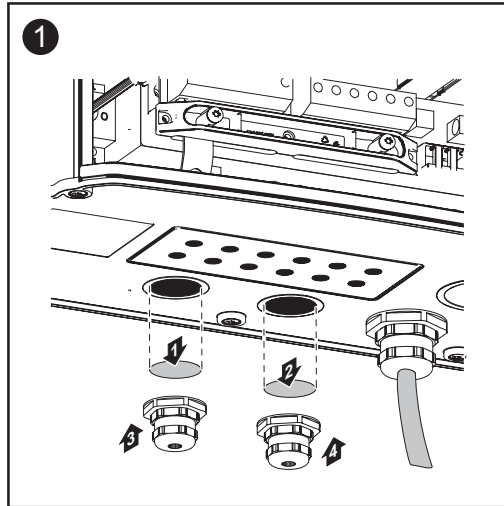

Solar Module Ground at Negative Pole: Connecting Solar Module Strings with a Cable Cross Section > 16 mm²

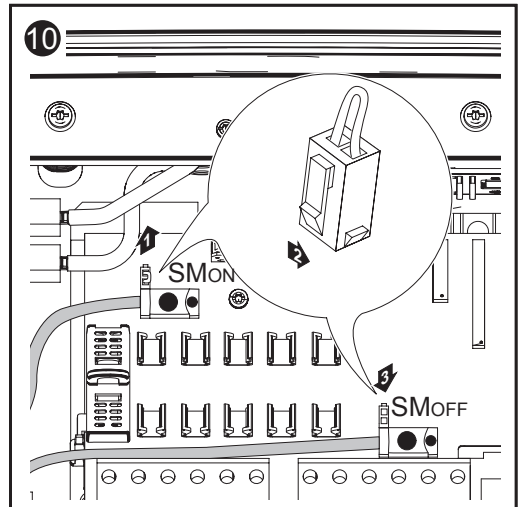
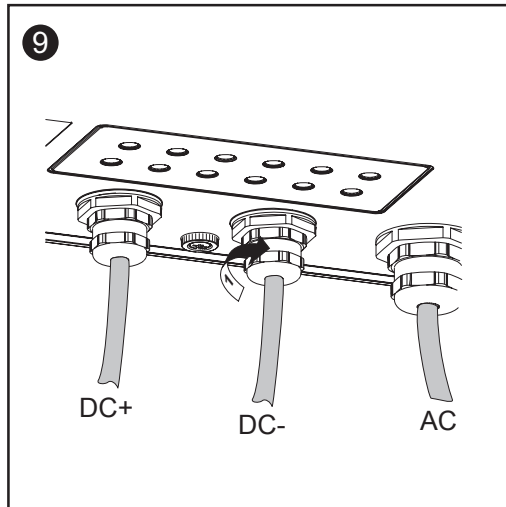
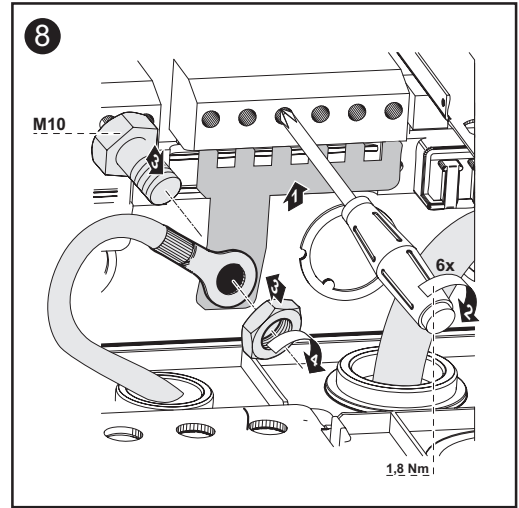
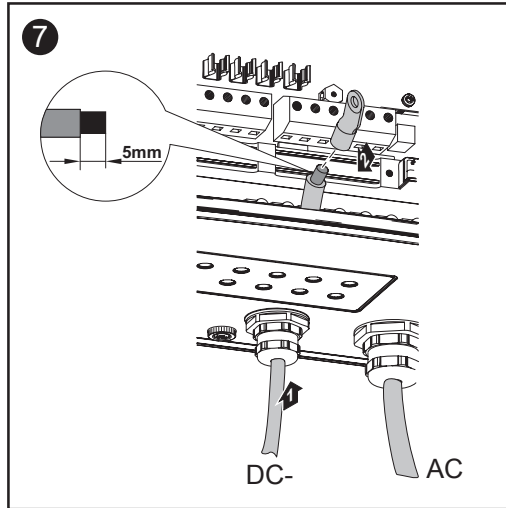

Important

- Set the jumper from the 'SMON' position to the 'SMOFF' position for correct measurement results
- Check the polarity and voltage of the DC cable: the voltage should be a max. of 600 V.

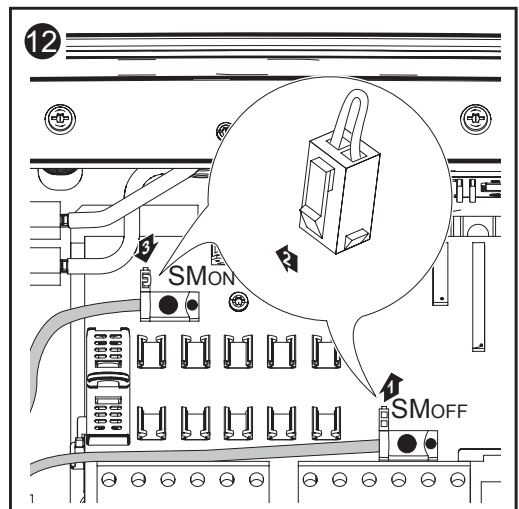
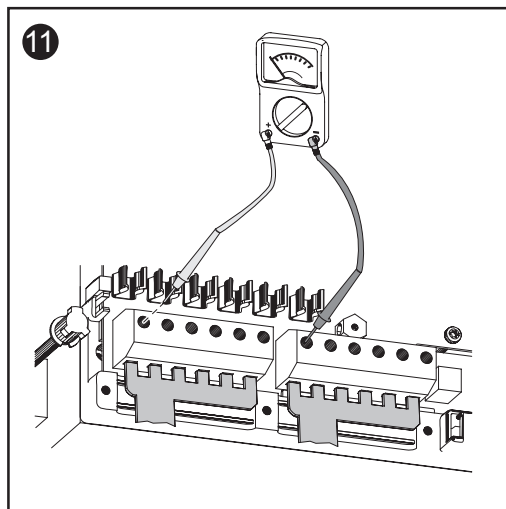

**Solar Module
Ground at
Negative Pole:
Connecting
Solar Module
Strings with a
Cable Cross
Section > 16
mm²**
(continued)

Important When using connection distributors, insert 6 metal bolts with fuse covers in the fuse holder. The metal bolts are included in the Fronius IG Plus scope of delivery.

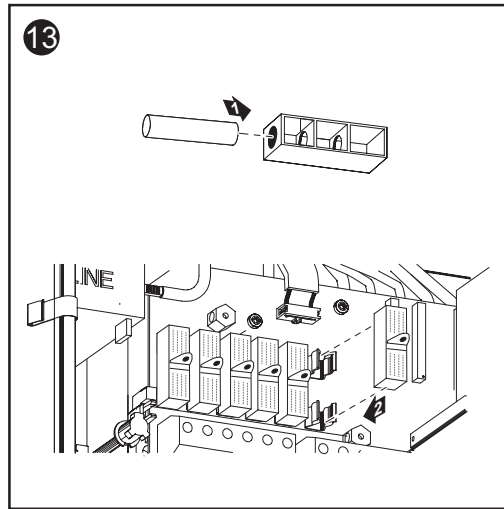

Solar Module Ground at Negative Pole for Fronius IG Plus

General

Some solar module manufacturers require that the solar modules be grounded.

Solar Module Ground at Negative Pole

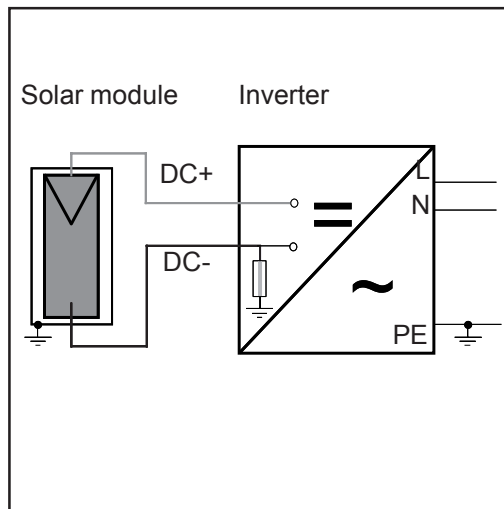

Example: Solar module ground at negative pole with fuse

Solar Module Ground at Negative Pole for Fronius IG Plus

You can ground solar modules in the Fronius IG Plus using a fuse.

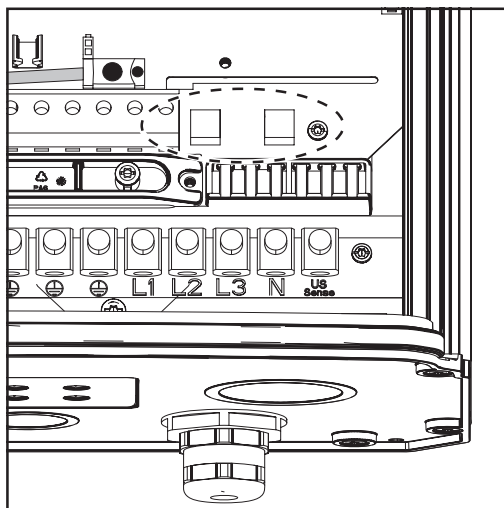

Fuse holder on the Fronius IG Plus for the solar module ground

Fronius recommends a fuse with 1 A and a dimension of 10 x 38 mm for solar module grounding.

Safety



WARNING! An electrical shock can be fatal. Danger from DC voltage from solar modules.

Inverter insulation monitoring is deactivated for grounded solar modules.

- Make sure that grounded solar modules are insulated according to protection class II
- Attach corresponding safety labels to the photovoltaic system where they can be seen easily
- Set the inverter so that an error message is displayed when the fuse is triggered.

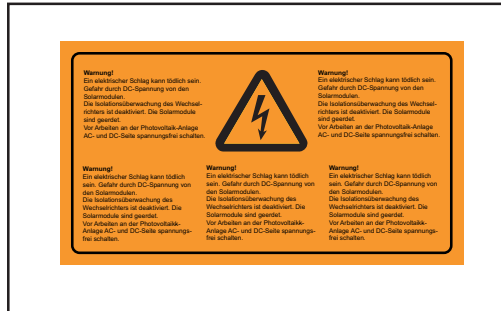

Safety label for the solar module ground

Important Safety labels and the fuse for solar module grounding are not included in the inverter scope of delivery, and must be obtained separately.

Setting Inverters for Grounded Solar Modules

Inverter insulation monitoring is deactivated if the solar modules are grounded. For this reason, you must make a setting in the 2nd level of the Setup menu so that an error message is displayed when the ground fuse is triggered. A code is required to access the 2nd level of the Setup menu. This code can be requested from Fronius. Additional information regarding accessing the 2nd level of the Setup menu will be provided along with the code.

Solar Module Ground: Inserting Fuses



NOTE If the solar module manufacturer requires a ground for solar modules at the negative pole:

- Insert the fuse with a fuse cover in the respective fuse holder
- Do not operate the Fronius IG Plus without fuse covers



WARNING! An electrical shock can be fatal. Danger from DC voltage from solar modules.

Fuse covers are for installation purposes only. They offer no protection against contact.

The DC main switch is only used to switch off power to the power module. When the DC main switch is turned off, the solar module ground at the negative pole remains unaffected. Never touch the DC+ and DC-

Solar Module Ground: Inserting Fuses (continued)

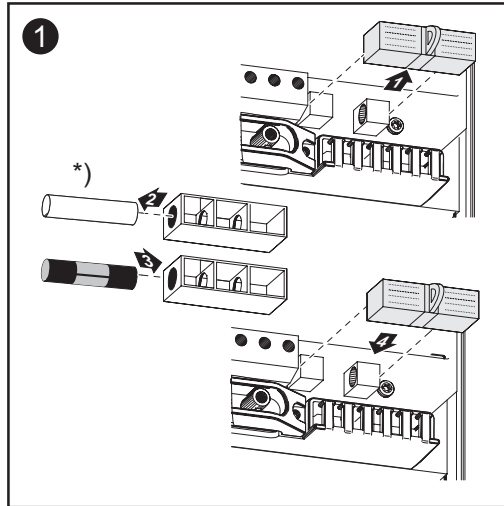

Fronius recommends a fuse with 1 A and a dimension of 10 x 38 mm for solar module grounding.

*) Plastic bolts are included in the Fronius IG Plus scope of delivery.

Inserting the fuse will ground the solar module at the negative pole.

Opening Fronius IG Plus for Service/Maintenance

Procedure for opening the Fronius IG Plus for service or maintenance:

1. Disconnect the AC and DC sides from the inverter
2. Open the connection area
3. Turn off DC main switch
4. Remove plate covers
5. Allow the capacitors to discharge (5 minutes)
6. If present, remove the fuse for the solar module ground
7. If present, remove string fuses
8. Disconnect DC cable
9. Disconnect AC cable

Solar Module Ground at Positive Pole: Connecting Solar Module Strings

General

The following work step is only necessary when the solar module manufacturer requires a solar module ground at the positive pole.

Cable Cross Section of Solar Module Strings

The cable cross section for solar module strings should be a maximum of 16 mm² per cable.

Solar Module Ground at Positive Pole: Connecting Solar Module Strings

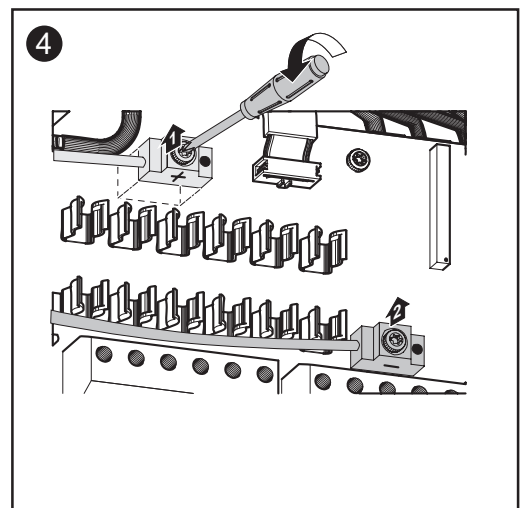
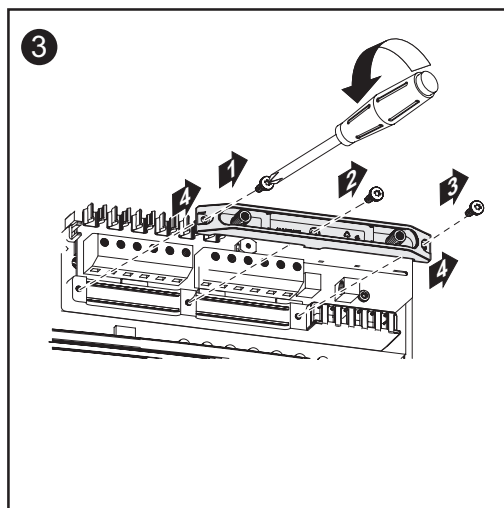
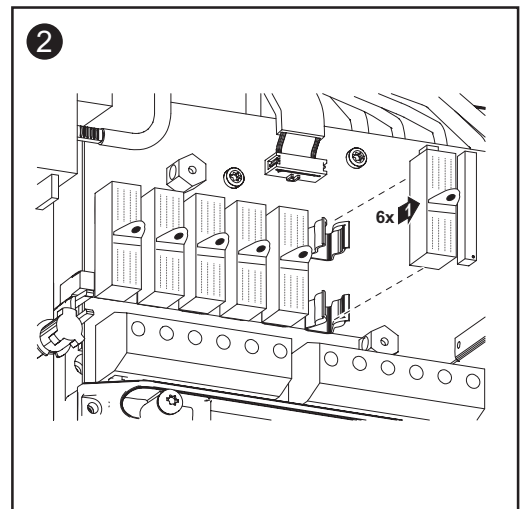
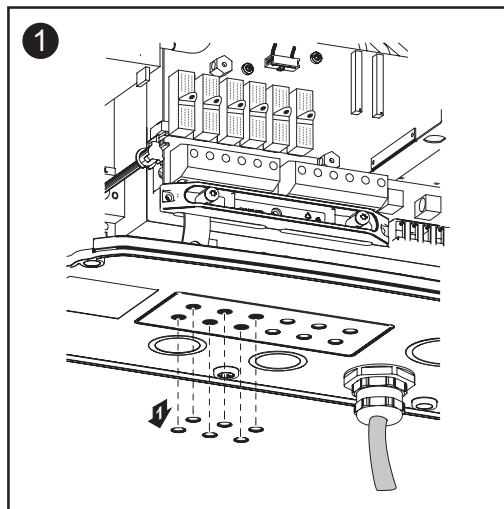

Solar Module Ground at Positive Pole: Connecting Solar Module Strings
(continued)

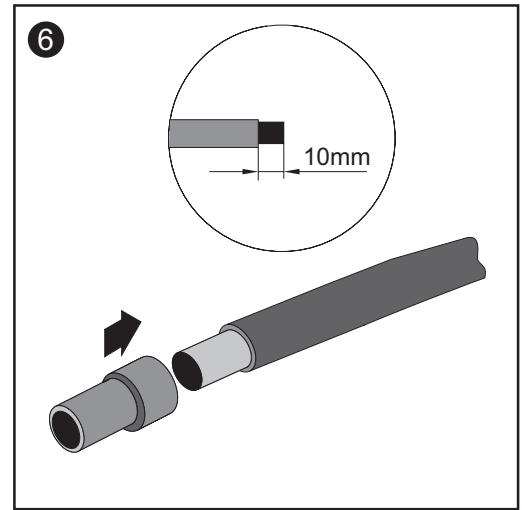
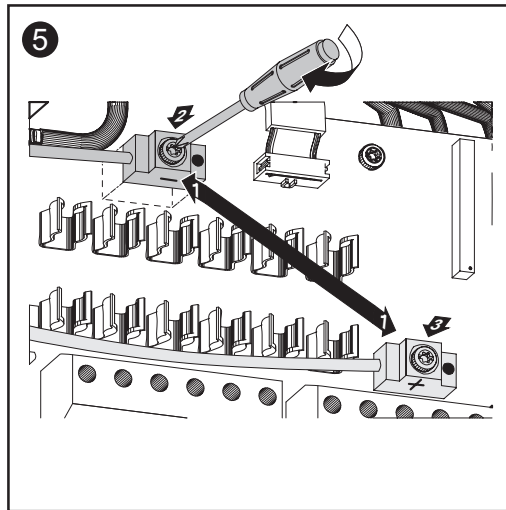

After disconnecting the DC main switch cable:

- Connect the DC+ cable to the DC- connection as per work step 5
- Connect the DC- cable to the DC+ connection as per work step 5



NOTE Identify the reversed polarity accordingly with (+) and (-).

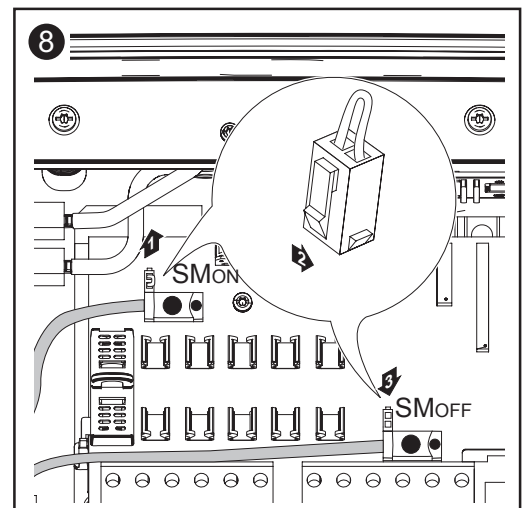
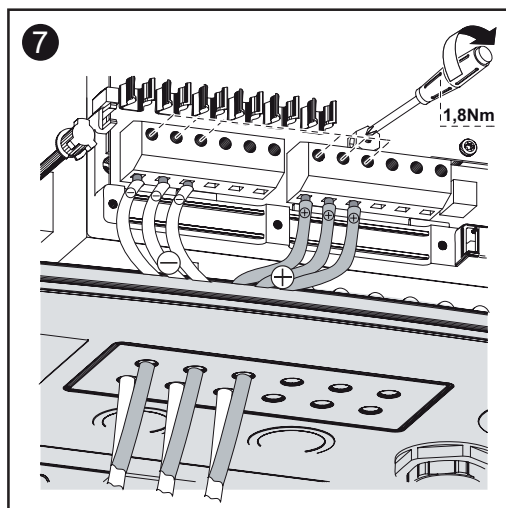

Important

- Set the jumper from the 'SMON' position to the 'SMOFF' position for correct measurement results
- Check the polarity and voltage of the solar module strings: the voltage should be a max. of 600 V, the difference between the individual solar module strings should be a max. of 10 V.

Solar Module Ground at Positive Pole: Connecting Solar Module Strings
(continued)

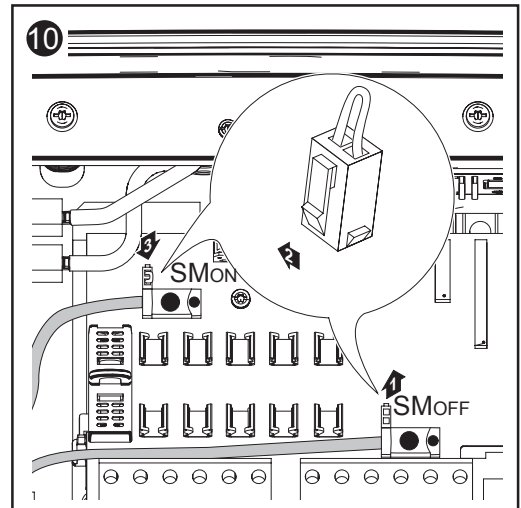
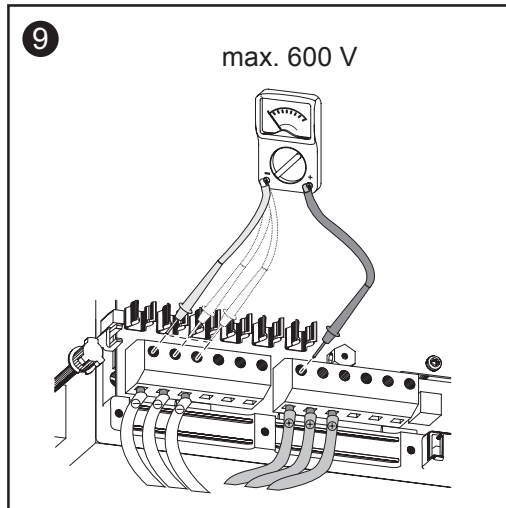

Important

- When connecting solar module strings, you should use metal bolts or string fuses with fuse covers in the fuse holder depending on the solar module manufacturer instructions. The metal bolts are included in the Fronius IG Plus scope of delivery.
- Place metal bolts with fuse covers in the fuse holders for unoccupied DC+ terminals.

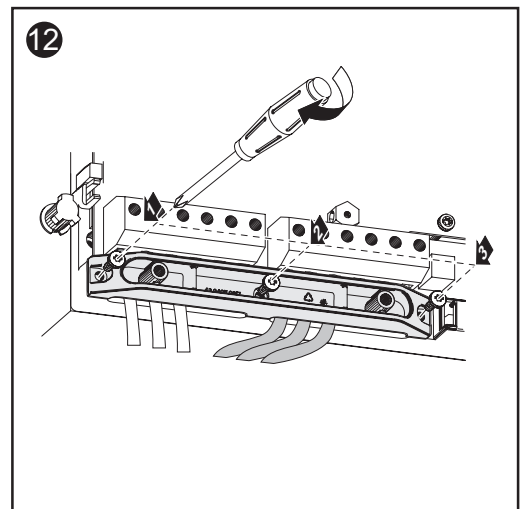
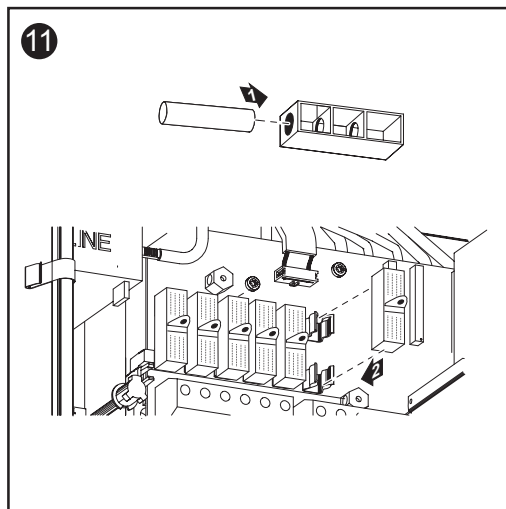

Selecting String Fuses

If the solar module manufacturer requires the use of string fuses for operation:

- Select string fuses according to the information from the solar module manufacturer or as per 'Criteria for the Proper Selection of String Fuses' (max. 20 A per solar module string, max. 6 solar module strings)

Important

- Please follow solar module safety instructions
- Please follow all solar module manufacturer requirements

Using String Fuses in Fronius IG Plus



NOTE If the solar module manufacturer requires the use of string fuses:

- Insert fuses with a fuse cover in the respective fuse holder
- Do not operate the Fronius IG Plus without fuse covers



WARNING! An electrical shock can be fatal. Danger from DC voltage from solar modules.

Fuse covers are for installation purposes only. They offer no protection against contact.

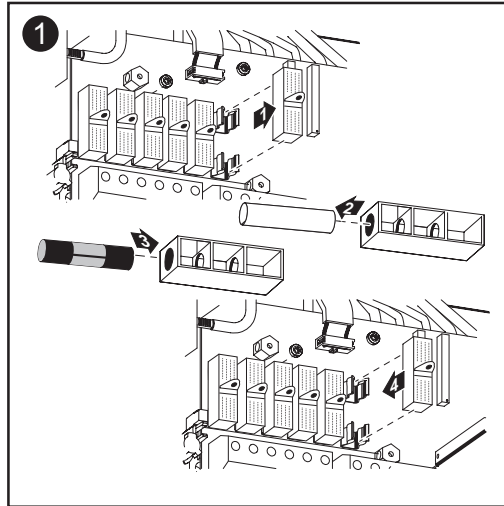

Criteria for the Proper Selection of String Fuses

General

The use of string fuses in the inverter also adds fuse protection to the solar modules.

A crucial factor for the fuse protection of solar modules is the maximum short circuit current (I_{SC} or STC) of the respective solar module.

Criteria for the Proper Selection of String Fuses

The following criteria must be fulfilled for each solar module string when using fuse protection:

- $I_N > 1.5 \times I_{SC}$
- $I_N < 2.00 \times I_{SC}$
- $U_N \geq 600 \text{ V DC}$
- Fuse dimensions: Diameter 10.3 x 35 - 38 mm

I_N Nominal current rating of fuse

I_{SC} also STC, short circuit current for standard test conditions according to solar module datasheet

U_N Nominal voltage rating of fuse

Effects of using underrated fuses

In underrated fuses, the nominal current value is less than the short circuit current of the solar module.

Effect:

The fuse may trip in intensive lighting conditions.

Fuse Recommendations - Application Example



NOTE Only select fuses suitable for a voltage of 600 V DC.

e.g.: Maximum short circuit current (I_{SC}) of the solar module = 5.75 A

According to the criteria for selecting the correct fuse, the fuse must have a nominal current greater than 1.5 times the short circuit current:

$$5.75 \text{ A} \times 1.5 = 8.625 \text{ A}$$

The fuse that should be selected according to the 'Fuses' table: KLK D 9 with 9.0 A and 600 V AC / DC

Fuses

Nominal current value	Fuse	Nominal current value	Fuse
1.0 A	KLK D 1	6.0 A	KLK D 6
1.5 A	KLK D 1 $\frac{1}{2}$	7.0 A	KLK D 7
2.0 A	KLK D 2	8.0 A	KLK D 8
2.5 A	KLK D 2 $\frac{1}{2}$	9.0 A	KLK D 9
3.0 A	KLK D 3	10.0 A	KLK D 10
3.5 A	KLK D 3 $\frac{1}{2}$	12.0 A	KLK D 12
4.0 A	KLK D 4	15.0 A	KLK D 15
5.0 A	KLK D 5	20.0 A	KLK D 20

'Fuses' table: Excerpt of suitable fuses, e.g. Littelfuse fuses

Solar Module Ground at Positive Pole: Connecting Solar Module Strings with a Cable Cross Section > 16 mm²

General

The following work step is only necessary when the solar module manufacturer requires a solar module ground at the positive pole.

As an option, you can also connect DC cables to the Fronius IG Plus with a cross section > 16 mm², e.g. when the DC cables from the solar modules are combined outside of the inverter leads into a large string.

Additional Required Components

The following additional components are required for connecting DC cables with a cross section > 16 mm²:

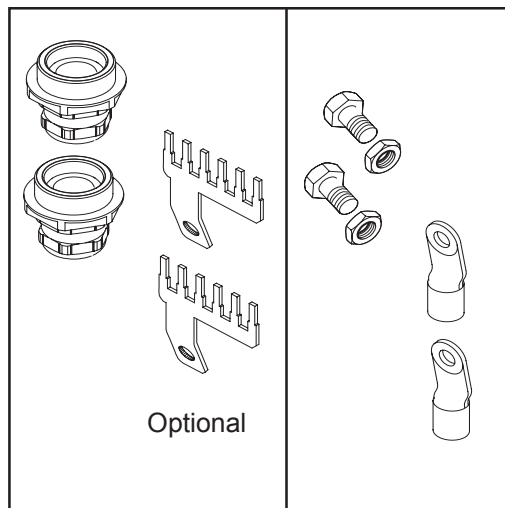

Additional Required Components

- 2 metric screw joints M32 (degree of protection min. IP45)
- 2 connection distributors
- metric screw joints and connection distributors are available from Fronius as an option
- 2 cable lugs for the DC cables
- select cable lugs that match the available DC cables
- 2 M10 screws
- 2 M10 hexagon nuts

Solar Module Ground at Positive Pole: Connecting Solar Module Strings with a Cable Cross Section > 16 mm²

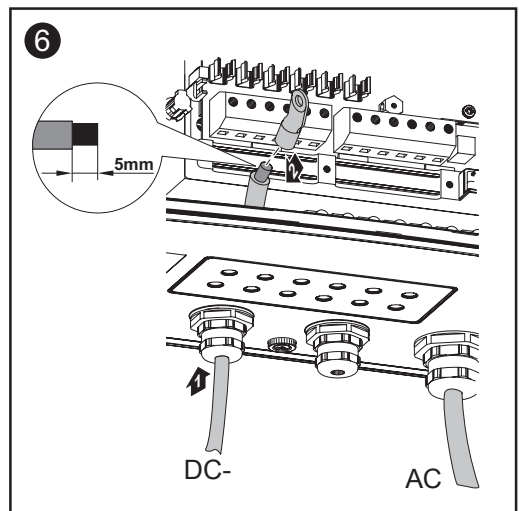
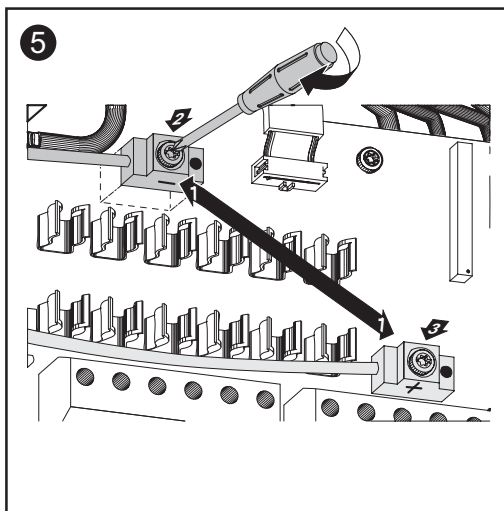
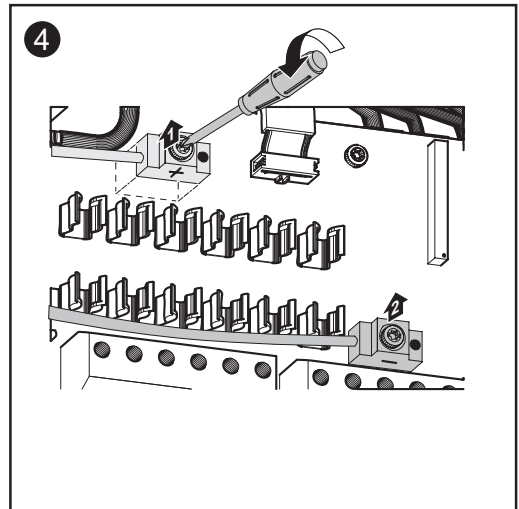
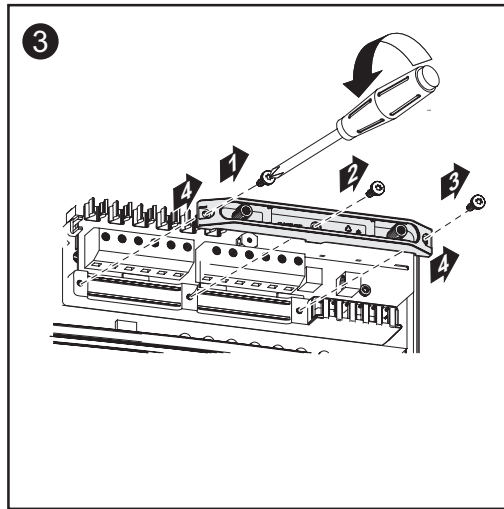
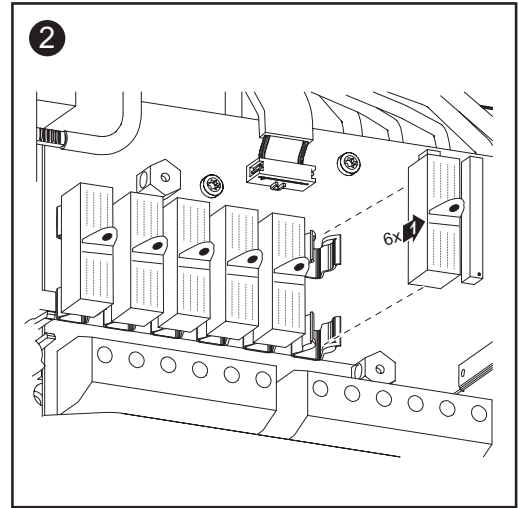
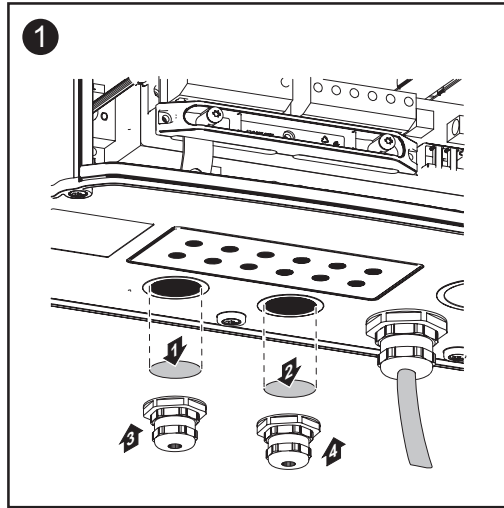

After disconnecting the DC main switch cable:

- Connect the DC+ cable to the DC- connection as per work step 5
- Connect the DC- cable to the DC+ connection as per work step 5



NOTE Identify the reversed polarity accordingly with (+) and (-).

Solar Module Ground at Positive Pole: Connecting Solar Module Strings with a Cable Cross Section > 16 mm²
(continued)

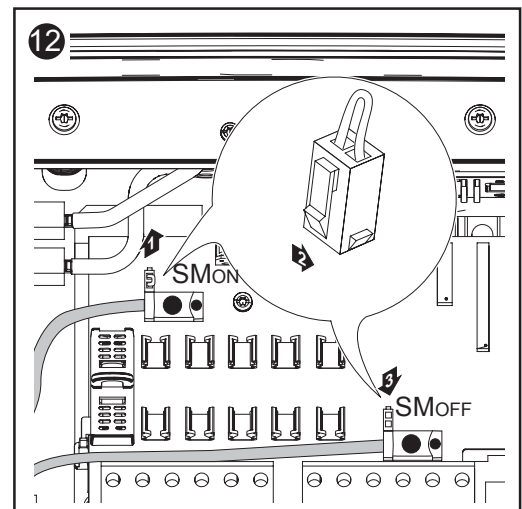
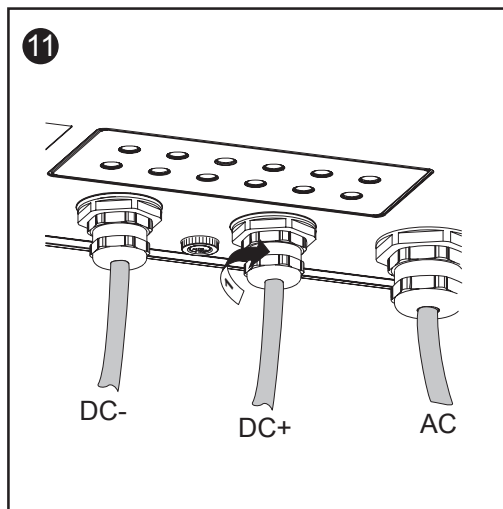
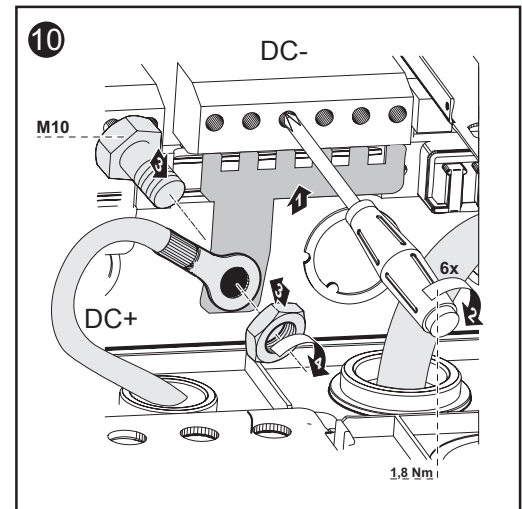
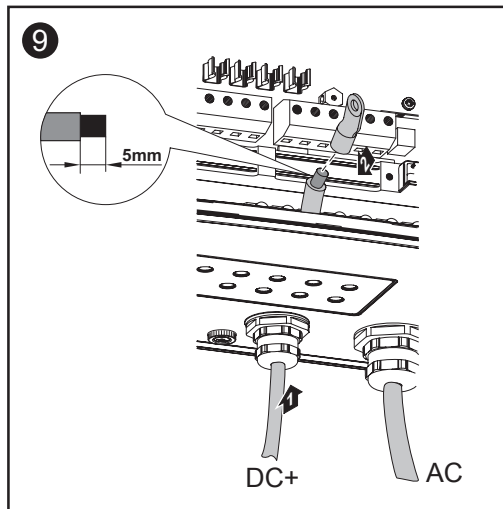
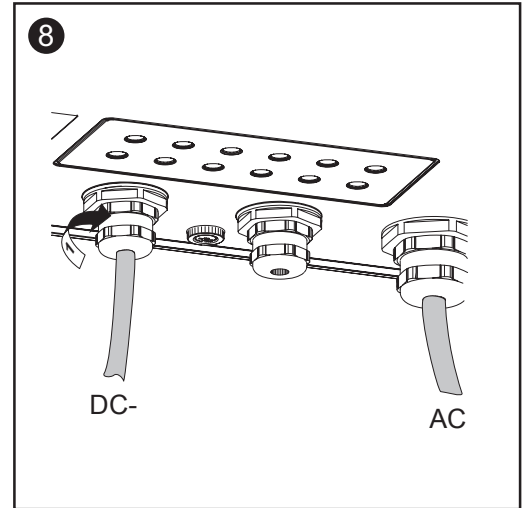
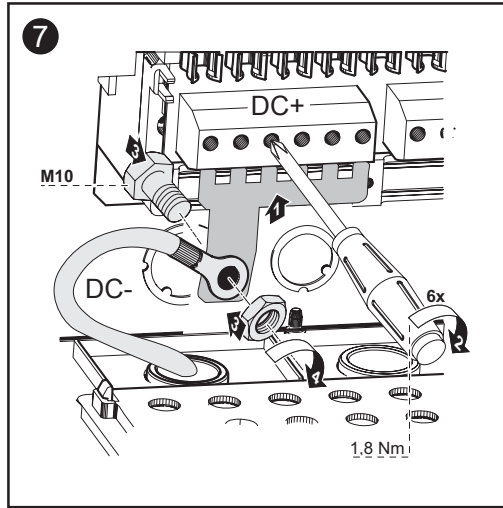

Important

- Set the jumper from the 'SMON' position to the 'SMOFF' position for correct measurement results
- Check the polarity and voltage of the DC cable: the voltage should be a max. of 600 V.

**Solar Module
Ground at
Positive Pole:
Connecting
Solar Module
Strings with a
Cable Cross
Section > 16
mm²**
(continued)

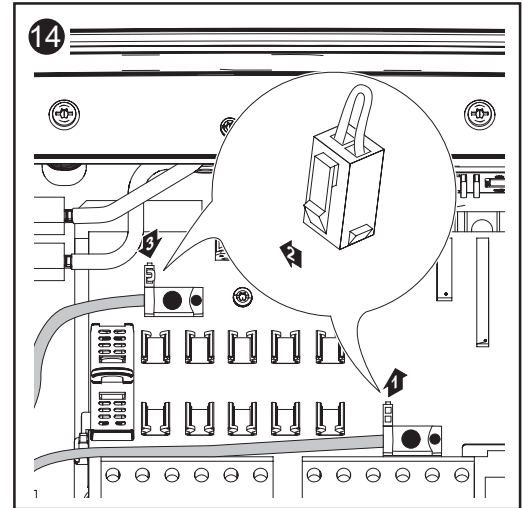
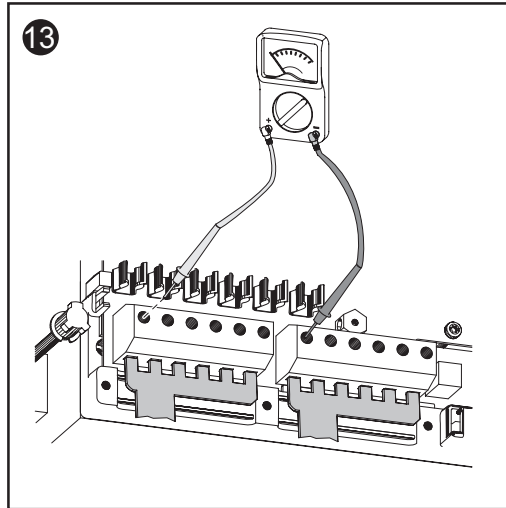

Important! When using connection distributors (copper plate), insert 6 metal bolts with fuse covers in the fuse holder. The metal bolts are included in the Fronius IG Plus scope of delivery.

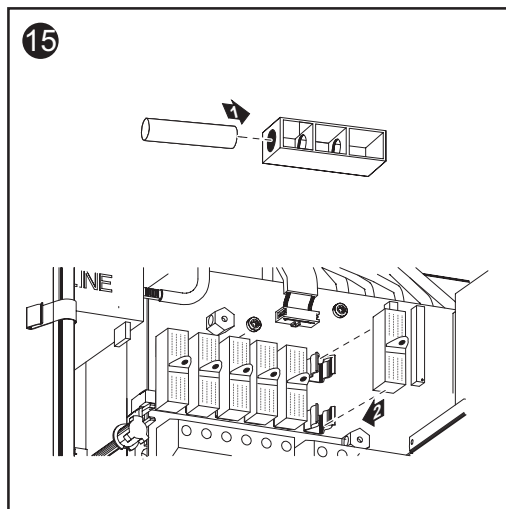

Solar Module Ground at Positive Pole for Fronius IG Plus

General

Some solar module manufacturers require that the solar modules be grounded.

Solar Module Ground at Positive Pole

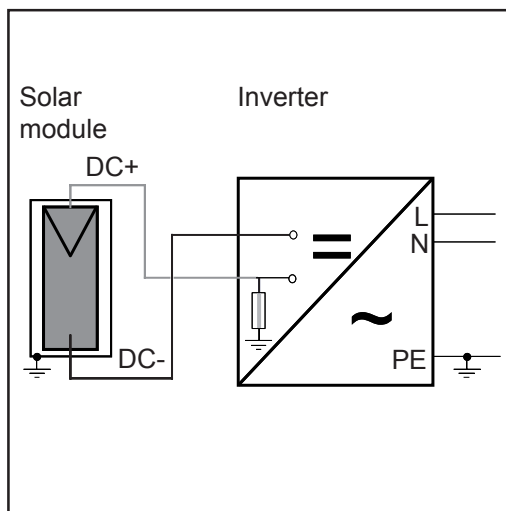

Example: Solar module ground at positive pole with fuse

Solar Module Ground at Positive Pole for Fronius IG Plus

You can ground solar modules in the Fronius IG Plus using a fuse.

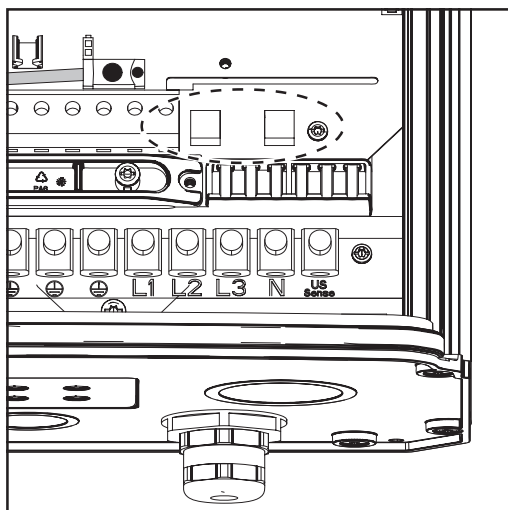

Fuse holder on the Fronius IG Plus for the solar module ground

Fronius recommends a fuse with 1 A and a dimension of 10 x 38 mm for solar module grounding.

Safety



WARNING! An electrical shock can be fatal. Danger from DC voltage from solar modules.

Inverter insulation monitoring is deactivated for grounded solar modules.

- Make sure that grounded solar modules are insulated according to protection class II
- Attach corresponding safety labels to the photovoltaic system where they can be seen easily
- Set the inverter so that an error message is displayed when the fuse is triggered.

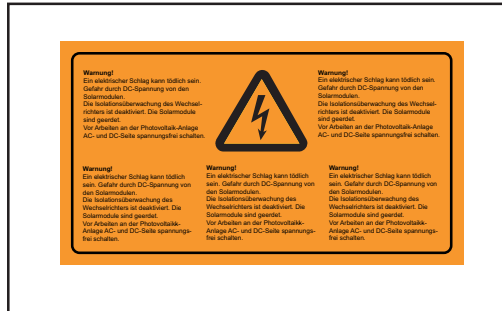

Safety label for the solar module ground

Important Safety labels and the fuse for solar module grounding are not included in the inverter scope of delivery, and must be obtained separately.

Setting Inverters for Grounded Solar Modules

Inverter insulation monitoring is deactivated for grounded solar modules. For this reason, you must make a setting in the 2nd level of the Setup menu so that an error message is displayed when the ground fuse is triggered. A code is required to access the 2nd level of the Setup menu. This code can be requested from Fronius. Additional information regarding accessing the 2nd level of the Setup menu will be provided along with the code.

Solar Module Ground: Inserting Fuses



NOTE If the solar module manufacturer requires a ground for solar modules at the positive pole:

- Insert the fuse with a fuse cover in the respective fuse holder
- Do not operate the Fronius IG Plus without fuse covers



WARNING! An electrical shock can be fatal. Danger from DC voltage from solar modules.

Fuse covers are for installation purposes only. They offer no protection against contact.

The DC main switch is only used to switch off power to the power module. When the DC main switch is turned off, the solar module ground at the negative pole remains unaffected. Never touch the DC+ and DC-

Solar Module Ground: Inserting Fuses (continued)

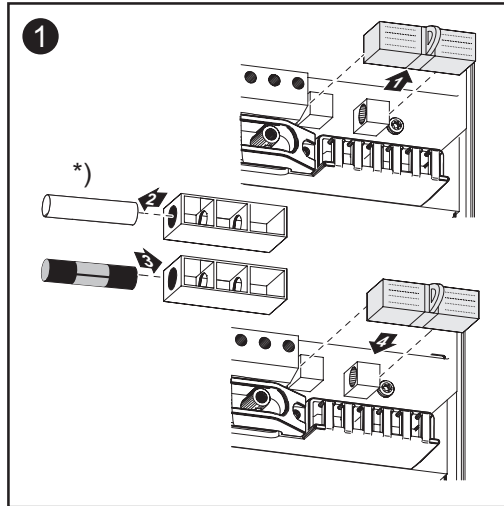

Fronius recommends a fuse with 1 A and a dimension of 10 x 38 mm for solar module grounding.

*) Plastic bolts are included in the Fronius IG Plus scope of delivery.

Inserting the fuse will ground the solar module at the positive pole.

Opening Fronius IG Plus for Service/Maintenance

Procedure for opening the Fronius IG Plus for service or maintenance:

1. Disconnect the AC and DC sides from the inverter
2. Open the connection area
3. Turn off DC main switch
4. Remove plate covers
5. Allow the capacitors to discharge (5 minutes)
6. If present, remove the fuse for the solar module ground
7. If present, remove string fuses
8. Disconnect DC cable
9. Disconnect AC cable

Closing Fronius IG Plus

Closing Fronius IG Plus

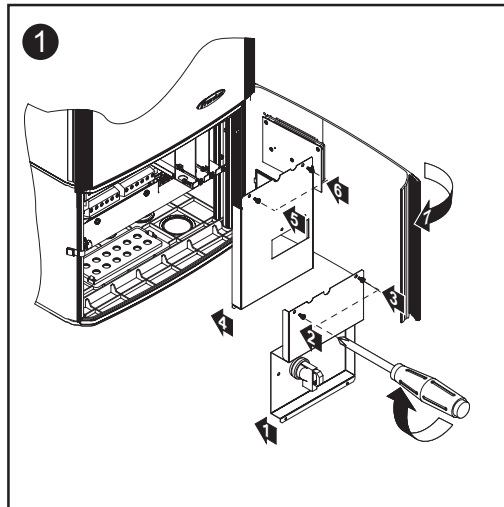

Inserting Option Cards

Suitable Option Cards

There are several options and system upgrades available for the Fronius IG Plus, e.g.:

- Datalogger and modem interface (for using a PC to record and manage data from your photovoltaic system)
- Various large displays (public display)
- Actuators / relays / alarms (signal card)
- Sensors (temperature / insolation / energy meter)

System upgrades come in the form of plug-in cards. The Fronius IG Plus can be equipped with three option cards.

Safety



WARNING! An electrical shock can be fatal. Danger from mains voltage and DC voltage from solar modules.

- The connection area should only be opened by a licensed electrician.
- Before making any connections, make sure that the AC and DC sides are disconnected from the inverter.



WARNING! An electrical shock can be fatal. Danger from residual voltage from capacitors.

You must wait until the capacitors have discharged. Discharge takes 5 minutes.



NOTE Follow general ESD precautions when handling option cards.

Opening Fronius IG Plus

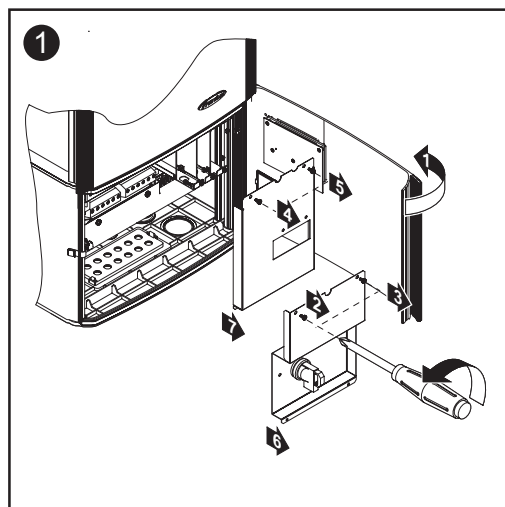

When adding option cards to the Fronius IG Plus, please follow all inverter safety instructions and information.

Inserting Option Cards

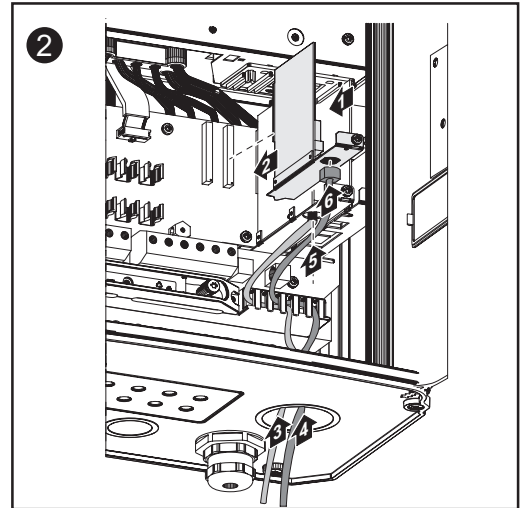
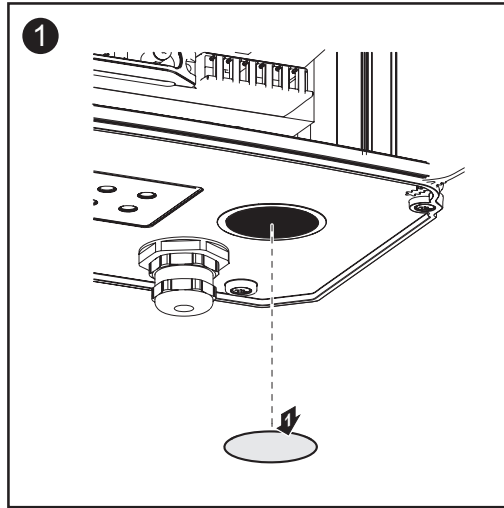

Important Depending on the number of option card cables, please use corresponding square sealing inserts.

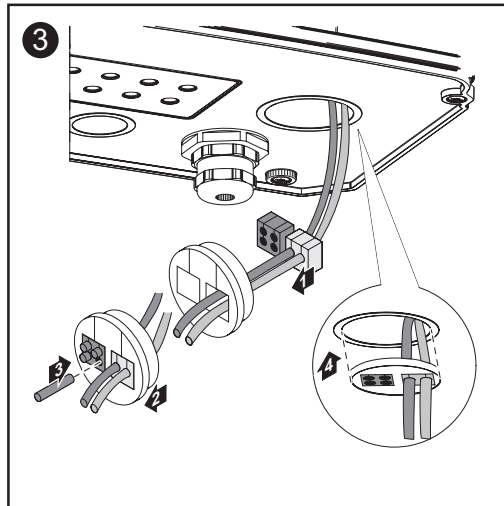

Square sealing inserts are part of the option card scope of delivery.

The round sealing insert is included in the 'COM card' option scope of delivery.

Closing Fronius IG Plus

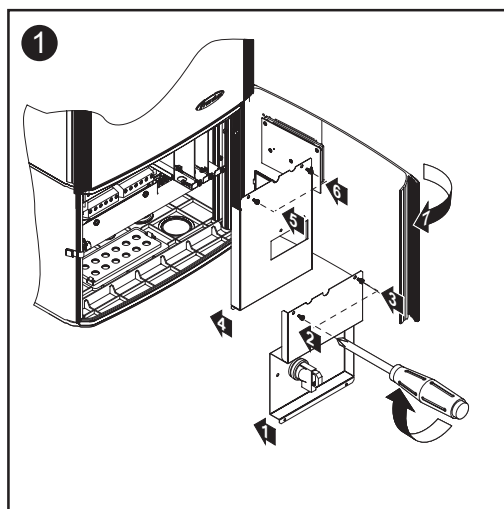

Solar Net and Data Interface

Fronius developed Solar Net to make these add-on system components flexible and capable of being used in a wide variety of different applications. Solar Net is a data network which enables several Fronius IG Plus units to be linked with the system upgrades.

Solar Net is a bus system. A single cable is all that is required for one or more Fronius IG Plus units to communicate with all system upgrade components.

The heart of Solar Net is the **Datalogger**. It coordinates data traffic and makes sure that even large amounts of data are distributed quickly and securely.

The '**COM Card**' option is required to integrate Fronius IG Plus into Solar Net.

Important Every Fronius IG Plus that is to be monitored using a Datalogger requires a 'COM Card.' In this case, the 'COM Card' serves as a link between the internal network of the Fronius IG Plus and the Solar Net interface of the Datalogger.

Important Each inverter can only have one 'COM card.' A network may only contain one Datalogger.

The first Fronius IG Plus with a 'COM card' can be up to 1000 m (3280 ft) away from the last Fronius IG Plus with a 'COM card.'

Different system upgrades are detected automatically by Solar Net.

In order to distinguish between several identical system upgrades, each one must be assigned a unique number.

In order to uniquely define each Fronius IG Plus in Solar Net, each Fronius IG Plus must also be assigned an individual number. You can assign individual numbers as per 'The Setup Menu' section in this manual.

More detailed information on the individual system upgrades can be found in the relevant operating instructions or on the Internet at www.fronius.com.

Example

Logging and archiving data from the inverter and sensor using a Datalogger and sensor box.

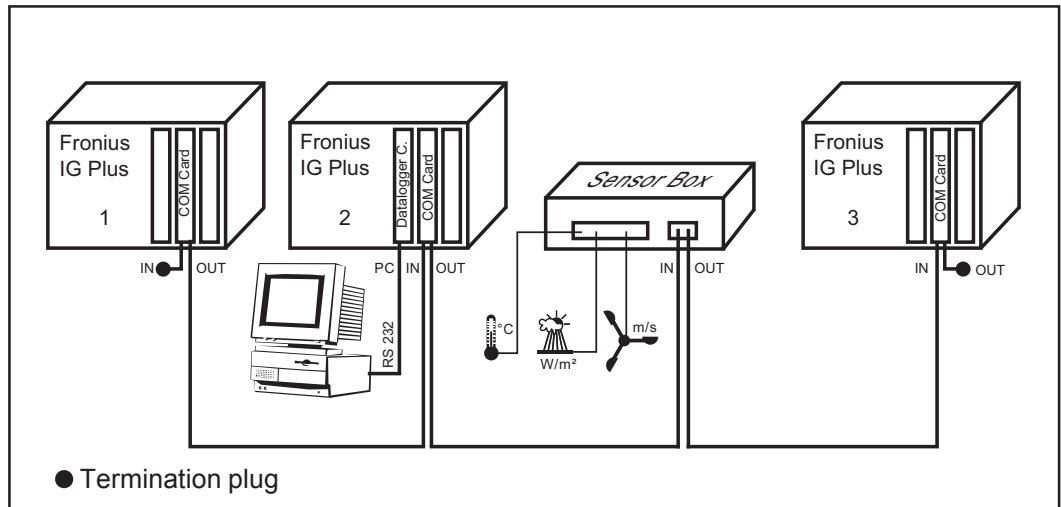

Data network with 3 Fronius IG Plus units and one sensor box:

- all Fronius IG Plus units have one 'COM Card'
- one Fronius IG Plus has a 'Datalogger card' (no. 2)
- Datalogger has two RS-232 interfaces for connecting to a PC and a modem

Option cards communicate within the Fronius IG Plus via its internal network. External communication (Solar Net) takes place via the 'COM cards.' Each 'COM card' is equipped with two RS485 interfaces - an input and an output. RJ45 plug connectors are used to connect to these cards.

Commissioning

Factory Configuration

The Fronius IG Plus has been pre-configured at the factory and is ready to use.

You can assign individual numbers as per 'The Setup Menu' section in this manual.

Commissioning

Once the Fronius IG Plus has been connected to the solar modules (DC) and the public grid (AC), turn the main switch to position - 1 -.



NOTE Regardless of whether bolts or fuses are used, do not operate the Fronius IG Plus without fuse covers.

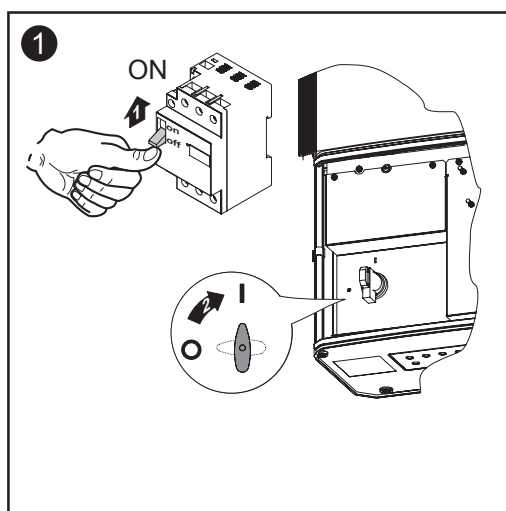

- If the solar modules are supplying enough power, the Operating Status LED will light up orange. The startup phase will be shown on the display. When the LED lights up orange, this indicates that the Fronius IG Plus is about to start up automatically.
- Once the Fronius IG Plus has completed its automatic startup, the LED will be green.
- Provided that power continues to feed into the grid, the LED will remain green to confirm that the Fronius IG Plus is functioning correctly.

Troubleshooting and Maintenance

Status Diagnosis and Troubleshooting

Display of Status Messages

The Fronius IG Plus is able to perform a system self diagnostic that automatically detects many errors that may occur and shows them on the display. This enables you to know immediately if there are any malfunctions in the Fronius IG Plus, the photovoltaic system or any installation or operating errors.

When the system self diagnostics detects a specific fault, the associated status message will appear on the display.

Important Status messages may sometimes appear briefly as a result of the control response from the Fronius IG Plus. If the Fronius IG Plus continues to operate without any sign of a problem, this means that there was no error.

General Status Messages

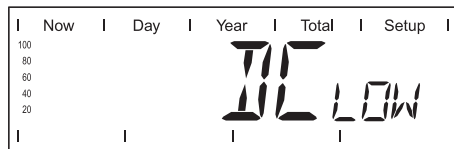

The open-circuit voltage of the solar modules is too low.

If the open-circuit voltage of the solar modules increases to over 290 V, the Fronius IG Plus will start synchronizing with the grid (display 'SYNCAC').

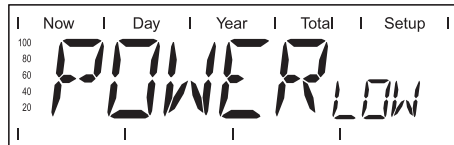

Power at the solar modules is too low

After a short wait, the Fronius IG Plus will resume grid synchronization (display: 'SYNCAC').

Total failure

If the display remains dark for a longer time after sunrise:

- Check the open-circuit voltage of the solar modules at the connections of the Fronius IG Plus:

Open-circuit voltage < 290 V ... error in the other photovoltaic system

Open-circuit voltage > 290 V ... may indicate a basic fault in the Fronius IG Plus. In this case, notify a Fronius-trained service technician.

Status Messages for a Fronius IG Plus with Several Power Modules

If an error occurs in a Fronius IG Plus with more than one power module, then a specific status message will be displayed.

Status messages can also be accessed even when there is no fault. Information on reviewing the status can be found in 'The Setup Menu' section of this manual.

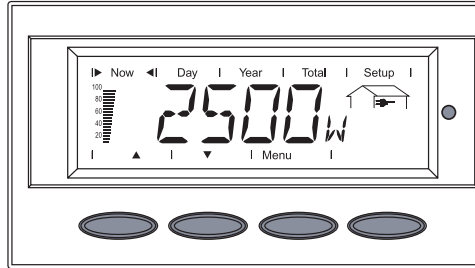

Display during normal operation

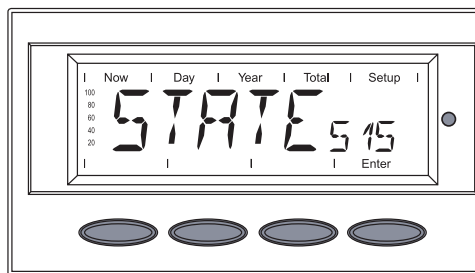

When there is an error in one of the two power modules, the display flashes between 'STATE' and the corresponding status message (e.g. 'STATE 515')

and

'ENTER'

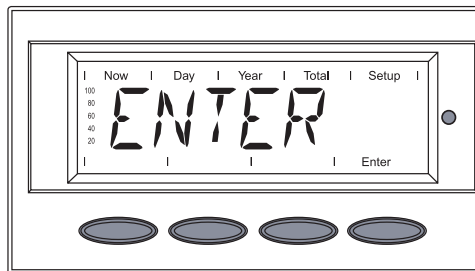

- Press the 'Enter' key twice

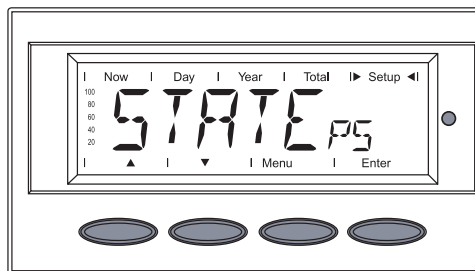

- The power module status display appears 'STATEPS'
- Press the 'Enter' key

Additional information can be found in 'The Setup Menu' section, STATEPS' Menu Option

**Status
Messages -
Class 1**

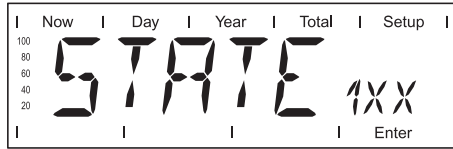

Class 1 status messages generally only occur momentarily, and are caused by the public grid.

The initial response of the Fronius IG Plus in this case is to disconnect itself from the grid. The grid is then checked for the stipulated monitoring period. If no further problem has been detected by the end of this period, the Fronius IG Plus will resume feeding power into the grid.

Important The 2nd position x defines the exact network point for the following status messages:

- 0 = several / all 3 phases
- 1 = L1
- 2 = L2
- 3 = L3

1x2

AC voltage too high

Behavior Grid conditions will be thoroughly tested and as soon as they are again within the permissible range, the Fronius IG Plus will resume feeding power into the grid.

Remedy Check grid connections and fuses
If this status message keeps recurring, contact your system installer

1x3

AC voltage too low

Behavior Grid conditions will be thoroughly tested and as soon as they are again within the permissible range, the Fronius IG Plus will resume feeding power into the grid.

Remedy Check grid connections and fuses
If this status message keeps recurring, contact your system installer

1x5

AC frequency too high

Behavior Grid conditions will be thoroughly tested and as soon as they are again within the permissible range, the Fronius IG Plus will resume feeding power into the grid.

Remedy Check grid connections and fuses
If this status message keeps recurring, contact your system installer

**Status
Messages -
Class 1**
(continued)

1x6

AC frequency too low

Behavior Grid conditions will be thoroughly tested and as soon as they are again within the permissible range, the Fronius IG Plus will resume feeding power into the grid.

Remedy Check grid connections and fuses
If this status message keeps recurring, contact your system installer

1x7

Behavior Grid conditions will be thoroughly tested and as soon as they are again within the permissible range, the Fronius IG Plus will resume feeding power into the grid.

Remedy Check grid connections and fuses
If this status message keeps recurring, contact your system installer

108

Islanding detected

Behavior Grid conditions will be thoroughly tested and as soon as they are again within the permissible range, the Fronius IG Plus will resume feeding power into the grid.

Remedy If this status message keeps recurring, contact your system installer

109

General grid error

This error is always displayed first for grid errors. After reviewing all power modules, the grid error will be specified with more detail: 1x1 / 1x4 or the display remains at '109' (e.g. when 2 phases report '104' and one phase '101')

Behavior Grid conditions will be thoroughly tested and as soon as they are again within the permissible range, the Fronius IG Plus will resume feeding power into the grid.

Remedy Check grid connections and fuses
If this status message keeps recurring, contact your system installer

**Status
Messages -
Class 3**

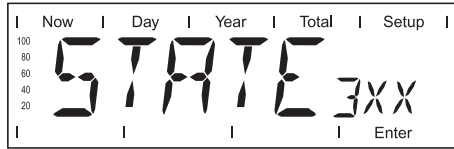

Class 3 status messages include conditions that may occur while feeding power into the grid, but generally do not cause the process to be interrupted for any length of time.

The Fronius IG Plus disconnects automatically from the grid. The grid is then monitored as specified and the Fronius IG Plus then attempts to resume feeding power.

301

Overcurrent (AC)

Behavior	Short-term interruption to grid power feed due to excess current Fronius IG Plus resumes its boot routine
Remedy	Error is corrected automatically If this status message keeps recurring, contact your system installer

302

Overcurrent (DC)

Behavior	Short-term interruption to grid power feed due to excess current Fronius IG Plus resumes its boot routine
Remedy	Error is corrected automatically If this status message keeps recurring, contact your system installer

303

Over-temperature buck converter

Behavior	Short-term interruption to grid power feed due to over-temperature Fronius IG Plus resumes its boot routine
Remedy	Error is corrected automatically If this status message keeps recurring, contact your system installer

304

Over-temperature heat sink

Behavior	Short-term interruption to grid power feed due to over-temperature Fronius IG Plus resumes its boot routine
Remedy	Error is corrected automatically If this status message keeps recurring, contact your system installer

**Status
Messages -
Class 3**
(continued)

305

No power transfer to grid because of closed grid relay

Behavior	Continual interruption of grid feed operation
Remedy	If this status message keeps recurring, contact your system installer

'POWER_{Low}' (306)

Intermediate circuit voltage too low for feed operation, this error is displayed on the Fronius IG Plus in plain text

Behavior	Short-term interruption of grid feed operation Fronius IG Plus resumes its boot routine
Remedy	Error is corrected automatically If this status message keeps recurring, contact your system installer

'DC_{Low}' (307)

DC input voltage too low for feed operation, this error is displayed on the Fronius IG Plus in plain text

Behavior	Short-term interruption of grid feed operation Fronius IG Plus resumes its boot routine
Remedy	Error is corrected automatically If this status message keeps recurring, contact your system installer

308

Intermediate circuit voltage too high

Behavior	Short-term interruption of grid feed operation Fronius IG Plus resumes its boot routine
Remedy	Error is corrected automatically If this status message keeps recurring, contact your system installer

Status Messages - Class 4

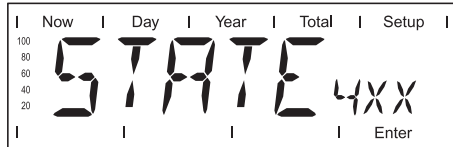

Some class 4 status messages require intervention by a trained Fronius service technician.

401

Communication with power module not possible

Behavior	The Fronius IG Plus will automatically attempt to connect again and, if possible, resume feeding power into the grid
Remedy	If the status message remains on the display: notify a Fronius-trained service technician

402

Communication with EEPROM not possible

Behavior	The Fronius IG Plus will automatically attempt to connect again and, if possible, resume feeding power into the grid
Remedy	If the status message remains on the display: notify a Fronius-trained service technician

403

EEPROM defective

Behavior	The Fronius IG Plus will automatically attempt to connect again and, if possible, resume feeding power into the grid
Remedy	If the status message remains on the display: notify a Fronius-trained service technician

406

One or both temperature sensors are defective

Behavior	The Fronius IG Plus will disconnect from the grid for safety reasons
Remedy	If the status message remains on the display: notify a Fronius-trained service technician

407

Temperature sensor at heat sink is defective

Behavior	The Fronius IG Plus will disconnect from the grid for safety reasons
Remedy	If the status message remains on the display: notify a Fronius-trained service technician

408

Direct current feed

Behavior	The Fronius IG Plus will disconnect from the grid for safety reasons
Remedy	If the status message remains on the display: notify a Fronius-trained service technician

**Status
Messages -
Class 4**
(continued)

412	Fixing voltage mode has been selected instead of MPP voltage mode, and the fixing voltage is set too low.
Behavior	The fixing voltage is lower than the current MPP voltage
Remedy	Check the module voltage and change the solar module connection if the input voltage is too high If the status message remains on the display: notify a Fronius-trained service technician

413	Control problems
Behavior	Because grid conditions have changed significantly, the Fronius IG Plus is disconnected briefly from the grid.
Remedy	If the status message remains on the display: notify a Fronius-trained service technician

414	EEPROM defective
Behavior	Memory component erased
Remedy	If the status message remains on the display: notify a Fronius-trained service technician

416	Communication with IG Brain not possible
Behavior	The Operating Status LED lights up orange, then the Fronius IG Plus attempts a restart
Remedy	If the status message remains on the display: notify a Fronius-trained service technician

417	Two power modules have the same PCB number
Behavior	The Fronius IG Plus stops feeding power into the grid, the display shows a critical error via a red Operating Status LED
Remedy	If the status message remains on the display: notify a Fronius-trained service technician

419	Two or more power modules with an identical software serial number detected
Behavior	The Fronius IG Plus stops feeding power into the grid, the display shows a critical error via a red Operating Status LED
Remedy	If the status message remains on the display: notify a Fronius-trained service technician

**Status
Messages -
Class 4**
(continued)

421	
PCB number has been set incorrectly	
Behavior	The Fronius IG Plus stops feeding power into the gird, the display shows a critical error via a red Operating Status LED
Remedy	If the status message remains on the display: notify a Fronius-trained service technician

425	
Communication with the power module is not possible	
Behavior	The Operating Status LED lights up orange, then the Fronius IG Plus attempts a restart
Remedy	If the status message remains on the display: notify a Fronius-trained service technician

431	
All power modules are in boot mode	
Behavior	The Fronius IG Plus stops feeding power into the gird, the display shows a critical error via a red Operating Status LED
Remedy	Update firmware using Bootloader or IG.Update

442	
No phase master for a phase	
Behavior	The Fronius IG Plus stops feeding power into the gird, the display shows a critical error via a red Operating Status LED
Remedy	If the status message remains on the display: notify a Fronius-trained service technician

443	
Energy transfer not possible	
Behavior	The Fronius IG Plus stops feeding power into the gird, the display shows a critical error via a red Operating Status LED
Remedy	If the status message remains on the display: notify a Fronius-trained service technician

445	
Invalid power module configuration	
Behavior	The Fronius IG Plus stops feeding power into the gird, the display shows a critical error via a red Operating Status LED
Remedy	If the status message remains on the display: notify a Fronius-trained service technician

**Status
Messages -
Class 4**
(continued)

450	
The monitoring of the power module main processor 'Guard' is active	
Behavior	The Fronius IG Plus stops feeding power into the gird, the display shows a critical error via a red Operating Status LED
Remedy	If the status message remains on the display: notify a Fronius-trained service technician

451	
The EEPROM Guard Control is defective	
Behavior	The Fronius IG Plus stops feeding power into the gird, the display shows a critical error via a red Operating Status LED
Remedy	If the status message remains on the display: notify a Fronius-trained service technician

452	
Communication between 'Guard' and the digital signal processor (DSP) has been interrupted	
Behavior	The Fronius IG Plus stops feeding power into the gird, the display shows a critical error via a red Operating Status LED
Remedy	If the status message remains on the display: notify a Fronius-trained service technician

453	
Error in mains voltage recording	
Behavior	The Fronius IG Plus stops feeding power into the gird, the display shows a critical error via a red Operating Status LED
Remedy	If the status message remains on the display: notify a Fronius-trained service technician

454	
Error in mains frequency recording	
Behavior	The Fronius IG Plus stops feeding power into the gird, the display shows a critical error via a red Operating Status LED
Remedy	If the status message remains on the display: notify a Fronius-trained service technician

455	
Reference power source for AC measurement is operating outside of tolerances	
Behavior	The Fronius IG Plus stops feeding power into the gird, the display shows a critical error via a red Operating Status LED
Remedy	If the status message remains on the display: notify a Fronius-trained service technician

**Status
Messages -
Class 4**
(continued)

456	
Error during anti-islanding test	
Behavior	The Fronius IG Plus stops feeding power into the gird, the display shows a critical error via a red Operating Status LED
Remedy	If the status message remains on the display: notify a Fronius-trained service technician

457	
Grid relay stuck	
Behavior	The Fronius IG Plus stops feeding power into the gird, the display shows a critical error via a red Operating Status LED
Remedy	If the status message remains on the display: notify a Fronius-trained service technician

460	
Reference power source for the digital signal processor (DSP) is operating outside of tolerances	
Behavior	The Fronius IG Plus stops feeding power into the gird, the display shows a critical error via a red Operating Status LED
Remedy	If the status message remains on the display: notify a Fronius-trained service technician

461	
Error in DSP data memory	
Behavior	The Fronius IG Plus stops feeding power into the gird, the display shows a critical error via a red Operating Status LED
Remedy	If the status message remains on the display: notify a Fronius-trained service technician

464	
Display error	
The software and/or hardware versions of the display and IG Brain are not compatible.	
Behavior	The Fronius IG Plus stops feeding power into the gird, the display shows a critical error via a red Operating Status LED
Remedy	Update firmware using Bootloader or IG.Update

465	
Display error	
The UI command sent from the IG Brain is not recognized by the current display version.	
Behavior	The Fronius IG Plus stops feeding power into the gird, the display shows a critical error via a red Operating Status LED
Remedy	If the status message remains on the display: notify a Fronius-trained service technician

**Status
Messages -
Class 4**
(continued)

466	
Display error	
The display was not detected.	
Behavior	The Fronius IG Plus stops feeding power into the gird, the display shows a critical error via a red Operating Status LED
Remedy	Check the display for damage, connect display, check ribbon cable for damage, check IG Brain for damage If the status message remains on the display: notify a Fronius-trained service technician

467	
The display has not received a start command from the IG Brain for longer than 6 s	
Behavior	The Fronius IG Plus will automatically attempt to connect again and, if possible, resume feeding power into the grid
Remedy	If the status message remains on the display: notify a Fronius-trained service technician

469	
Throttle connected to wrong poles	
Behavior	The Fronius IG Plus stops feeding power into the gird, the display shows a critical error via a red Operating Status LED
Remedy	Properly connect throttle If the status message remains on the display: notify a Fronius-trained service technician

470	
The buck converter relay does not open at high DC voltage	
Behavior	The Fronius IG Plus stops feeding power into the gird, the display shows a critical error via a red Operating Status LED
Remedy	Check system configuration If the status message remains on the display: notify a Fronius-trained service technician

Status Messages - Class 4
(continued)

471

Defective fuse for the solar module ground has not yet been replaced. This status message is displayed when the fuse for the solar module ground has not been replaced within a certain period of time after status message 551 is triggered.

Behavior	The Fronius IG Plus stops feeding power into the grid, the display shows a critical error via a red Operating Status LED
Remedy	Insert a new fuse for the solar module ground to ground solar modules at the negative and positive poles. Error is corrected automatically If this status message keeps recurring, contact your system installer

Status Messages - Class 5

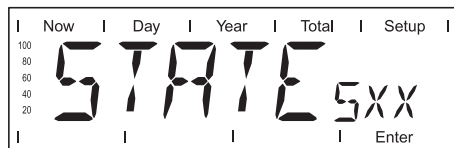

Class 5 status messages do not generally interfere with feed operation. A status message is displayed until it is acknowledged by pressing a key (however, the Fronius IG Plus continues to operate normally in the background).

- Press any key
- The error message disappears from the display

501

One of the two fans is defective

Behavior	Full output is not achieved
Remedy	If the status message remains on the display: notify a Fronius-trained service technician

502

Insulation value too low

Description	While automatically measuring the insulation, the Fronius IG Plus has detected an insulation fault to the ground
Remedy	Check the insulation of your photovoltaic system The status message reappears: Contact your system installer

**Status
Messages -
Class 5**
(continued)

504	
Communication with Solar Net not possible	
Description	Fronius IG Plus address has been assigned twice
Remedy	Change Fronius IG Plus address (section: 'The Setup Menu')
Description	The Solar Net components required are in the Fronius IG Plus: However, no communication is possible
Remedy	Status message will disappear after changing the Fronius IG Plus address

505	
EEPROM defective	
Description	Data has been lost from the Setup menu
Remedy	Error corrected automatically

506	
EEPROM defective	
Description	Data has been lost from the 'Total' menu
Remedy	Error corrected automatically

507	
EEPROM defective	
Description	Data has been lost from the "Day"/"Year" menu
Remedy	Error corrected automatically

508	
Fronius IG Plus address contains an error	
Description	The address for data communication is no longer stored
Remedy	Reset address

509	
No power feed for 24 h	
Description	e.g.: Solar modules covered with snow
Remedy	e.g.: Remove snow from solar modules

510	
EEPROM defective	
Description	SMS settings have been reset to their defaults
Remedy	Reconfigure SMS if necessary

511	
EEPROM defective	
Description	Sensor card settings have been reset to their defaults
Remedy	Reconfigure measuring channels if necessary

**Status
Messages -
Class 5**
(continued)

512	
Too many power modules in the system	
Description	Too many power modules have been detected in the system
Remedy	If the status message remains on the display: notify a Fronius-trained service technician

513	
Power module in boot mode	
Description	One or more power modules cannot be activated because they are in boot mode.
Remedy	Update power module firmware

514	
No communication with one of the power modules	
Description	Warning message issued by one of the power modules, second power module is operating normally
Remedy	If the status message remains on the display: notify a Fronius-trained service technician

515	
Faulty plug connections	
Description	Temperature sensor at heat sink defective, service jumper at the 'Service' slot or '+15 V secondary' not connected
Remedy	If the status message remains on the display: notify a Fronius-trained service technician

516	
Status messages have been received from a power module	
Description	The power modules cannot all be activated
Remedy	Analyze the messages. Additional information can be found in 'The Setup Menu' section, STATE _{PS} ' menu option. If the status message remains on the display: notify a Fronius-trained service technician

517	
Master has been changed.	
Description	Transformer not connected/plugged in Jumper short circuit
Remedy	Recording of intermediate circuit voltage damaged Check for possible faults - listed under Description. If the status message remains on the display: notify a Fronius-trained service technician

550	
String fuse defective	
Description	One or more string fuses are defective
Remedy	Measure string fuses and replace any that are defective

**Status
Messages -
Class 5**
(continued)

550

Jumper set incorrectly

Description The jumper on the Print C-Box was not reset to the 'SMON' position after the solar module strings were checked

Remedy Set the jumper on the Print C-Box to the 'SMON' position

551

Fuse for solar module ground is defective

Description The fuse for the solar module ground is defective, replace the fuse to protect the solar module

Remedy Insert a new fuse for the solar module ground to ground solar modules at the negative and positive poles.

Error is corrected automatically

If this status message keeps recurring, contact your system installer

**Customer
Service**

Important! Please contact your Fronius dealer or a Fronius-trained service partner if

- an error appears frequently or for a long period of time
- an error appears that is not listed in the tables

Maintenance

Safety



WARNING! An electrical shock can be fatal. Danger from mains voltage and DC voltage from solar modules.

- The connection area should only be opened by a licensed electrician.
- The separate power module area should only be disconnected from the connection area after first being disconnected from the mains power.
- The separate power module area should only be opened by Fronius-trained service personnel.

Before making any connections, make sure that the AC and DC sides are disconnected from the inverter.

The DC main switch is only used to switch off power to the power module. When the DC main switch is turned off, the connection area is still energized.



WARNING! An electrical shock can be fatal. Danger from residual voltage from capacitors.

You must wait until the capacitors have discharged. Discharge takes 5 minutes.

General

The Fronius IG Plus is designed so that it does not require additional maintenance.

However, there are a few points to keep in mind during operation to ensure that the inverter functions optimally.

Operation in Environments with a Strong Formation of Dust

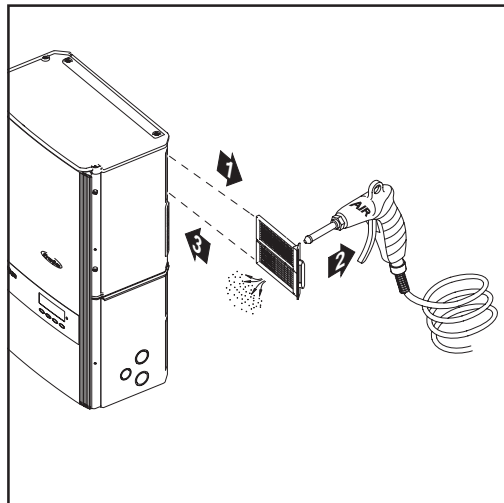

When operating the inverter in extremely dusty environments: Remove the fan cover and clean the integrated fly screen as required

Opening Fronius IG Plus for Service/ Maintenance

Procedure for opening the Fronius IG Plus for service or maintenance:

1. Disconnect the AC and DC sides from the inverter
2. Open the connection area
3. Turn off DC main switch
4. Remove plate covers
5. Allow the capacitors to discharge (5 minutes)
6. If present, remove the fuse for the solar module ground
7. If present, remove string fuses
8. Disconnect DC cable
9. Disconnect AC cable

Replacing String Fuses

Safety



WARNING! An electrical shock can be fatal. Danger from mains voltage and DC voltage from solar modules.

- The connection area should only be opened by a licensed electrician.
- Before making any connections, make sure that the AC and DC sides are disconnected from the inverter.
- The DC main switch is only used to switch off power to the power module. When the DC main switch is turned off, the connection area is still energized.



WARNING! An electrical shock can be fatal. Danger from residual voltage from capacitors.

You must wait until the capacitors have discharged. Discharge takes 5 minutes.

Before Installing

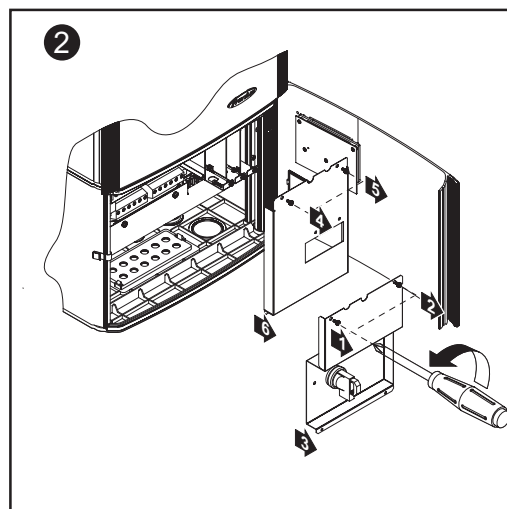
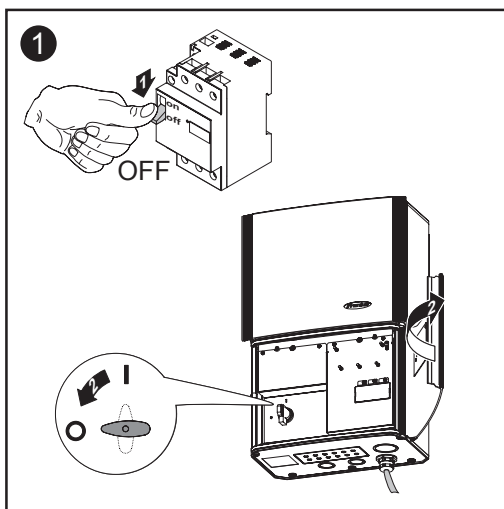

Replacing Fuses

- 1 Test the fuse holder at the terminal for continuity



NOTE Only use fuses for solar modules that meet the proper requirements for string fuses.

Fuse dimensions: Diameter 10.3 x 35 - 38 mm

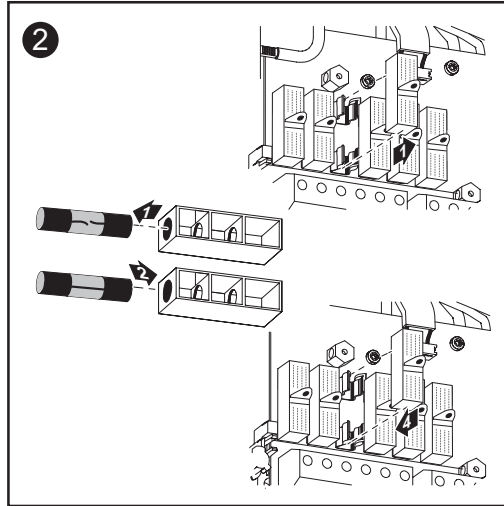

- 3 After replacing the fuse:
 - Find out and correct the cause for the defective fuse

Finally...

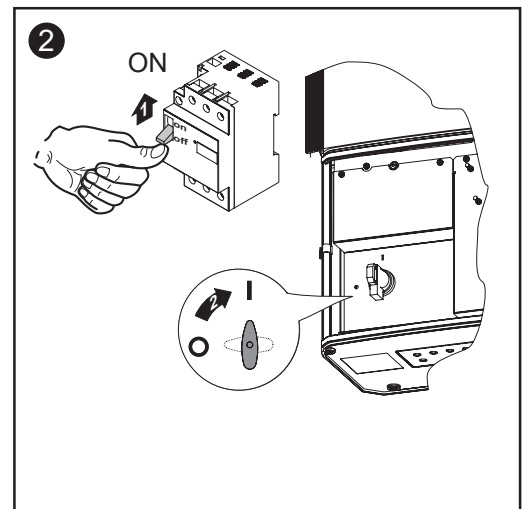
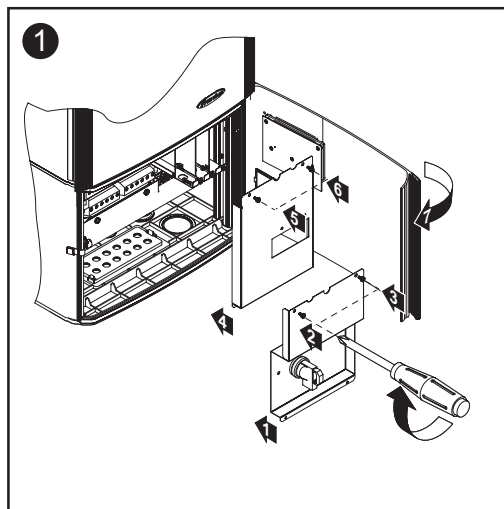

Appendix

Technical Data

Fronius IG Plus 35

Input data

MPP voltage range	230 - 500 V DC
Max. input voltage (at 1000 W/m ² / -10 °C (14 °F) in an open circuit)	600 V DC
Max. input current	16 A DC

Output data

Nominal output power (P _{nom})	3.5 kW
Max. output power	3.5 kW
Nominal mains voltage	1 ~ NPE 220 / 230 V, +10 / -15 % *)
Nominal output current (one phase)	15.9 / 15.2 A AC
Nominal frequency	50 - 60 Hz *)
Harmonic distortion	< 3.5 %
Power factor cos phi	1

General data

Maximum efficiency	96 %
Europ. max. efficiency	95.1 %
Power consumption at night	< 1 W
Cooling	Controlled forced ventilation
Protection class	IP 44
Dimensions l x w x h	244 x 434 x 631 mm (9.6 x 17.1 x 24.8 in)
Weight	25 kg (55.1 lb)
Permissible ambient temperature (with 95% rel. humidity)	-20 °C - +50 °C (-4 °F - +122 °F)

Protective equipment

DC insulation measurement	Warning when R _{ISO} < 500 KOHM
DC overvoltage protection	integrated
Protection against reversed polarity	integrated
Manifestation of DC overload	Operating point shift

*) The values provided are standard values. Upon request, the Fronius IG Plus can be customized to the respective country.

**Fronius IG
Plus 50**

Input data

MPP voltage range	230 - 500 V DC
Max. input voltage (at 1000 W/m ² / -10 °C (14 °F) in an open circuit)	600 V DC
Max. input current	18.3 A DC

Output data

Nominal output power (P_{nom})	4 kW
Max. output power	4 kW
Nominal mains voltage	1 ~ NPE 220 / 230 V, +10 / -15 % *)
Nominal output current (one phase)	18.2 / 17.4 A AC
Nominal frequency	50 - 60 Hz *)
Harmonic distortion	< 3.5 %
Power factor cos phi	1

General data

Maximum efficiency	96 %
Europ. max. efficiency	95.1 %
Power consumption at night	< 1 W
Cooling	Controlled forced ventilation
Protection class	IP 44
Dimensions l x w x h	244 x 434 x 631 mm (9.6 x 17.1 x 24.8 in)
Weight	25 kg (55.1 lb)
Permissible ambient temperature (with 95% rel. humidity)	-20 °C - +50 °C (-4 °F - +122 °F)

Protective equipment

DC insulation measurement	Warning when $R_{ISO} < 500$ kOHM
DC overvoltage protection	integrated
Protection against reversed polarity	integrated
Manifestation of DC overload	Operating point shift

*) The values provided are standard values. Upon request, the Fronius IG Plus can be customized to the respective country.

**Fronius IG
Plus 70**

Input data

MPP voltage range	230 - 500 V DC
Max. input voltage (at 1000 W/m ² / -10 °C (14 °F) in an open circuit)	600 V DC
Max. input current	29.7 A DC

Output data

Nominal output power (P _{nom})	6.5 kW
Max. output power	6.5 kW
Nominal mains voltage	1 ~ NPE 220 / 230 V, +10 / -15 % *) 2 ~ NPE 220 / 230 V, +10 / -15 % *)
Nominal output current	single phase 29.5 / 28.3 A AC two phase 14.8 / 14.1 A AC
Nominal frequency	50 - 60 Hz
Harmonic distortion	< 3.5 %
Power factor cos phi	1

General data

Maximum efficiency	96 %
Europ. max. efficiency	95.4 %
Power consumption at night	< 1 W
Cooling	Controlled forced ventilation
Protection class	IP 44
Dimensions l x w x h	244 x 434 x 962 mm (9.6 x 17.1 x 37.8 in)
Weight	38 kg (83.7 lb)
Permissible ambient temperature (with 95% rel. humidity)	-20 °C - +50 °C (-4 °F - +122 °F)

Protective equipment

DC insulation measurement	Warning when R _{ISO} < 500 kOHM
DC overvoltage protection	integrated
Protection against reversed polarity	integrated
Manifestation of DC overload	Operating point shift

*) The values provided are standard values. Upon request, the Fronius IG Plus can be customized to the respective country.

**Fronius IG
Plus 100**

Input data

MPP voltage range	230 - 500 V DC
Max. input voltage (at 1000 W/m ² / -10 °C (14 °F) in an open circuit)	600 V DC
Max. input current	36.6 A DC

Output data

Nominal output power (P _{nom})	8 kW
Max. output power	8 kW
Nominal mains voltage	1 ~ NPE 220 / 230 V, +10 / -15 % *) 2 ~ NPE 220 / 230 V, +10 / -15 % *)
Nominal output current	single phase 36.4 / 34.8 A AC two phase 18.2 / 17.4 A AC
Nominal frequency	50 - 60 Hz
Harmonic distortion	< 3.5 %
Power factor cos phi	1

General data

Maximum efficiency	96 %
Europ. max. efficiency	95.5 %
Power consumption at night	< 1 W
Cooling	Controlled forced ventilation
Protection class	IP 44
Dimensions l x w x h	244 x 434 x 962 mm (9.6 x 17.1 x 37.8 in)
Weight	38 kg (83.7 lb)
Permissible ambient temperature (with 95% rel. humidity)	-20 °C - +50 °C (-4 °F - +122 °F)

Protective equipment

DC insulation measurement	Warning when R _{ISO} < 500 kOHM
DC overvoltage protection	integrated
Protection against reversed polarity	integrated
Manifestation of DC overload	Operating point shift

*) The values provided are standard values. Upon request, the Fronius IG Plus can be customized to the respective country.

**Fronius IG
Plus 120**

Input data

MPP voltage range	230 - 500 V DC
Max. input voltage (at 1000 W/m ² / -10 °C (14 °F) in an open circuit)	600 V DC
Max. input current	45.78 A DC

Output data

Nominal output power (P _{nom})	10 kW
Max. output power	10 kW
Nominal mains voltage	3 ~ NPE 400 V, +10 / -15 % *)
Nominal output current (three phase)	15.2 / 14.5 A AC
Nominal frequency	50 - 60 Hz
Harmonic distortion	< 3.5 %
Power factor cos phi	1

General data

Maximum efficiency	96 %
Europ. max. efficiency	95.5 %
Power consumption at night	< 1 W
Cooling	Controlled forced ventilation
Protection class	IP 44
Dimensions l x w x h	244 x 434 x 1221 mm (9.6 x 17.1 x 48.1 in)
Weight	49 kg (108 lb)
Permissible ambient temperature (with 95% rel. humidity)	-20 °C - +50 °C (-4 °F - +122 °F)

Protective equipment

DC insulation measurement	Warning when R _{ISO} < 500 kOHM
DC overvoltage protection	integrated
Protection against reversed polarity	integrated
Manifestation of DC overload	Operating point shift

*) The values provided are standard values. Upon request, the Fronius IG Plus can be customized to the respective country.

**Fronius IG
Plus 150**

Input data

MPP voltage range	230 - 500 V DC
Max. input voltage (at 1000 W/m ² / -10 °C (14 °F) in an open circuit)	600 V DC
Max. input current	54.9 A DC

Output data

Nominal output power (P _{nom})	12 kW
Max. output power	12 kW
Nominal mains voltage	3 ~ NPE 400 V, +10 / -15 % *)
Nominal output current (three phase)	18.2 / 17.4 A AC
Nominal frequency	50 - 60 Hz
Harmonic distortion	< 3.5 %
Power factor cos phi	1

General data

Maximum efficiency	96 %
Europ. max. efficiency	95.5 %
Power consumption at night	< 1 W
Cooling	Controlled forced ventilation
Protection class	IP 44
Dimensions l x w x h	244 x 434 x 1221 mm (9.6 x 17.1 x 48.1 in)
Weight	49 kg (108 lb).
Permissible ambient temperature (with 95% rel. humidity)	-20 °C - +50 °C (-4 °F - +122 °F)

Protective equipment

DC insulation measurement	Warning when R _{ISO} < 500 kOHM
DC overvoltage protection	integrated
Protection against reversed polarity	integrated
Manifestation of DC overload	Operating point shift

*) The values provided are standard values. Upon request, the Fronius IG Plus can be customized to the respective country.

Relevant Standards and Directives

CE Mark	The equipment also complies with all the requisite and relevant standards and directives that form part of the relevant EU directive, and therefore is permitted to display the CE mark.
Parallel Operation of In-Plant Power Generation Systems	<p>The Fronius IG Plus complies with the</p> <ul style="list-style-type: none">- „Guidelines for connection and parallel operation of in-plant generation systems with the low-voltage grid“ published by the German Electricity Industry Association (VDEW)- “Technical guidelines for parallel operation of in-plant generation systems” published by the Austrian association of electricity companies.
Switching to Prevent Stand-alone Operation	The Fronius IG Plus has a circuit for preventing stand-alone operations which is approved by the professional association for precision and electronic engineering in accordance with DIN VDE 0126-1-1.
Grid Failure	The standard measurement and safety procedures integrated into the Fronius IG Plus ensure that the power feed is immediately interrupted in the event of a grid failure (shut-off by the utility or damage to lines).
Relevant Standards and Directives	<ul style="list-style-type: none">- „Safety requirements for photovoltaic energy generation plants“ (ÖNORM/ÖVE E2750), to the extent that these regulations are applicable to the inverter

Warranty and Disposal

Warranty Provisions and Liability

The Fronius IG Plus is covered by a warranty in accordance with the general terms and conditions. During this period, Fronius guarantees that the inverter will work correctly. If a defect should occur for which Fronius is responsible, Fronius will repair the defect at the factory free of charge within the warranty period.

Important! Fronius cannot provide compensation for power that has not been fed into the grid in the event of down-time.

Please see your Fronius dealer for warranty claims.

Exclusions to Warranty Claims

Warranty claims will not be accepted as a result of

- Improper use of solar inverter and its accessories
- Incorrect installation and installation that is not in compliance with applicable standards or installation by unlicensed electricians
- Incorrect operation
- The Fronius IG Plus is operated using defective protective equipment
- Unauthorized modifications to the Fronius IG Plus and accessories
- Foreign object damage and Acts of God (force majeure)

Warranty Claim Requirements

- Warranty claims will be handled by either Fronius directly or locally by Fronius-trained service partners.
- For return transportation, devices and/or components must be in their original or equivalent packaging.

These services will be charged to the dealer or his installer, as will the reinstallation of the repaired device.

When the faulty component is being repaired, if the cause of the defect is established as one not covered by warranty, then Fronius will charge for repairing the part (or for a replacement part) even if the warranty is still valid.

Scope of Warranty

The statutory warranty applies only to the Fronius IG Plus and the optional system upgrade components included in the scope of delivery. The other components of your photovoltaic system are not covered by this warranty.

**Scope of
Warranty**
(continued)

In addition, the warranty does not cover any damage to the Fronius IG Plus caused by other photovoltaic system components.

**Warranty
Period**

60 months from the date of installation

Exception: The optional system upgrades included in the scope of supply. For these, the warranty period is 24 months from the date of installation.

The warranty can be extended up to 10 years from the production date.

Extensions to the warranty period apply exclusively to the Fronius IG Plus. However, they do not apply to plug-in card system upgrades.

Replacement parts are covered by Fronius warranty for an additional period of 12 months even if the warranty period on the repaired Fronius IG Plus has already expired.

**Proof of War-
ranty**

The serial number of the Fronius IG Plus provides information regarding the validity of the warranty. However, to establish an unambiguous warranty claim, the sales invoice for the inverter and/or the photovoltaic system should be provided (positive identification of the respective inverter via its serial number).

Warranty service may not take place without a serial number.

Disposal

If you decide in the future to replace your inverter, Fronius will take back the old unit and arrange for it to be recycled in an appropriate way.



EU-KONFORMITÄTSERKLÄRUNG 2008
EC-DECLARATION OF CONFORMITY 2008
DECLARATION DE CONFORMITE DE LA CE, 2008

Wels-Thalheim, 2008-05-05

Die Firma

Manufacturer

La compagnie

FRONIUS INTERNATIONAL GMBH
Günter Fronius Straße 1, A-4600 Wels-Thalheim

erklärt in alleiniger Verantwortung,
dass folgendes Produkt:

Hereby certifies on it's sole
responsibility that the following
product:

se déclare seule responsable du fait
que le produit suivant:

Fronius IG Plus 35-1 / 50-1 /
70-1 / 70-2 / 100-1 / 100-2 /
120-3 / 150-3
Solar-Wechselrichter

Fronius IG Plus 35-1 / 50-1 /
70-1 / 70-2 / 100-1 / 100-2 /
120-3 / 150-3
Photovoltaic inverter

Fronius IG Plus 35-1 / 50-1 /
70-1 / 70-2 / 100-1 / 100-2 /
120-3 / 150-3
Onduleur solaire

auf das sich diese Erklärung
bezieht, mit folgenden Richtlinien
bzw. Normen übereinstimmt:

which is explicitly referred to by this
Declaration meet the following
directives and standard(s):

qui est l'objet de la présente
déclaration correspondent aux
suivantes directives et normes:

Richtlinie 2006/95/EG
Elektrische Betriebsmittel
Niederspannungsrichtlinie

Directive 2006/95/EC
Electrical Apparatus
Low Voltage Directive

Directive 2006/95/CE
Outillages électriques
Directive de basse tension

Richtlinie 2004/108/EG
Elektromag. Verträglichkeit

Directive 2004/108/EC
Electromag. compatibility

Directive 2004/108/CE
Électromag. compatibilité

Europäische Normen
EN 50178:1997
EN 61000-3-2:2000
EN 61000-3-11:2000
EN 61000-3-12:2005
EN 61000-6-2:2001
EN 61000-6-3:2001
EN 50366:2003

European Standard
EN 50178:1997
EN 61000-3-2:2000
EN 61000-3-11:2000
EN 61000-3-12:2005
EN 61000-6-2:2001
EN 61000-6-3:2001
EN 50366:2003

Norme européenne
EN 50178:1997
EN 61000-3-2:2000
EN 61000-3-11:2000
EN 61000-3-12:2005
EN 61000-6-2:2001
EN 61000-6-3:2001
EN 50366:2003

Die oben genannte Firma hält
Dokumentationen als Nachweis der
Erfüllung der Sicherheitsziele und
die wesentlichen Schutzanforder-
ungen zur Einsicht bereit.

Documentation evidencing
conformity with the requirements of
the Directives is kept available for
inspection at the above
Manufacture's.

En tant que preuve de la satisfaction
des demandes de sécurité la
documentation peut être consultée
chez la compagnie susmentionnée.

CE 2008

ppa. Mag.Ing.H.Hackl



**EC-DECLARATION OF CONFORMITY 2008
DECLARATION DE CONFORMITE DE LA CE, 2008
DECLARACIÓN DE CONFORMIDAD UE, 2008**

Wels-Thalheim, 2008-05-05

Manufacturer

Costruttore

La empresa

FRONIUS INTERNATIONAL GMBH
Günter Fronius Straße 1, A-4600 Wels-Thalheim

Hereby certifies on it's sole responsibility that the following product:

Con la presente certifica dichiara la sua esclusiva responsabilità che il seguente prodotto:

declara bajo su exclusiva responsabilidad que el siguiente producto:

Fronius IG Plus 35-1 / 50-1 / 70-1 / 70-2 / 100-1 / 100-2 / 120-3 / 150-3
Photovoltaic inverter

Fronius IG Plus 35-1 / 50-1 / 70-1 / 70-2 / 100-1 / 100-2 / 120-3 / 150-3
Inverter solare

Fronius IG Plus 35-1 / 50-1 / 70-1 / 70-2 / 100-1 / 100-2 / 120-3 / 150-3
Inversor solar

which is explicitly referred to by this Declaration meet the following directives and standard(s):

al quale è esplicitamente riferita questa dichiarazione, è conforme alle seguenti direttive e agli seguenti standard:

al que se refiere la presente declaración está conforme con las siguientes directivas y normas:

Directive 2006/95/EC
Electrical Apparatus
Low Voltage Directive
Directive 2004/108/EC
Electromag. compatibility

Direttiva 2006/95/CE
Materiale elettrico
Direttiva Bassa tensione
Direttiva 2004/108/CE
Compatibilità elettromagnetica

Directiva 2006/95/CE
Material eléctrico
Directiva de baja tensión
Directiva 2004/108/CE
Compatibilidad electromagnética

European Standard
EN 50178:1997
EN 61000-3-2:2000
EN 61000-3-11:2000
EN 61000-3-12:2005
EN 61000-6-2:2001
EN 61000-6-3:2001
EN 50366:2003

Norme standard europee
EN 50178:1997
EN 61000-3-2:2000
EN 61000-3-11:2000
EN 61000-3-12:2005
EN 61000-6-2:2001
EN 61000-6-3:2001
EN 50366:2003

Normas europeas
EN 50178:1997
EN 61000-3-2:2000
EN 61000-3-11:2000
EN 61000-3-12:2005
EN 61000-6-2:2001
EN 61000-6-3:2001
EN 50366:2003

Documentation evidencing conformity with the requirements of the Directives is kept available for inspection at the above Manufacture's

La documentazione attestante la conformità alle richieste delle direttive sarà tenuta a disposizione per ispezioni presso il sopracitato costruttore.

La empresa mencionada anteriormente tiene a disposición para inspección los documentos que confirman el cumplimiento de los objetivos de seguridad y los requisitos de protección esenciales.



Fachausschuss „Elektrotechnik“ • Postfach 510580 • 50941 Köln

Fronius International GmbH
Günter Fronius Str.1
4600 Wels
Austria

Ihr Zeichen
Ihre Nachricht vom
Unser Zeichen UB.010.17 PVOW
(bitte stets angeben)
Ansprechpartner/in Pohl
Telefon 0221 3778-6312
Fax 0221 3778-6322
E-Mail pohl.wolfgang@bgfe.de
Internet www.bgfe.de
Datum 12.11.2007

Unbedenklichkeitsbescheinigung 07013

Erzeugnis: Selbsttätig wirkende Schaltstelle

Typ: Fronius IG Plus, Setup DE

Bestimmungsgemäße

Verwendung: Selbsttätig wirkende, dem VNB unzugängliche Schaltstelle als Sicherheitsschnittstelle zwischen einer Eigenerzeugungsanlage und dem Niederspannungsnetz. Gleichwertiger Ersatz für eine jederzeit dem VNB zugängliche Schaltstelle mit Trennfunktion. Die Schaltstelle ist integraler Bestandteil der PV-Wechselrichter Typ: Fronius IG Plus

Prüfgrundlage:

DIN V VDE V 0126-1-1: 2006-02 „Selbsttätige Schaltstelle zwischen einer netzparallelen Erzeugungsanlage und dem öffentlichen Niederspannungsnetz“

Das mit Bericht vom 02.07.2007 Az. 2.04.00403.1.0 (arsenal research) geprüfte Sicherheitskonzept des o.g. Erzeugnisses, entspricht den zum Zeitpunkt der Ausstellung dieser Bescheinigung geltenden sicherheitstechnischen Anforderungen für die aufgeführte bestimmungsgemäße Verwendung.

Die Unbedenklichkeitsbescheinigung wird spätestens am

31.12.2012

ungültig.

- Mehlem -
Leiter der Prüf- und
Zertifizierungsstelle

Document of Compliance 07013

Product:	Automatic switching center
Type:	Fronius IG Plus, Setup DE
Intended Use:	Automatic switching center inaccessible to the DSO as a safety interface between an in-plant generation system and the low-voltage grid. Also a backup for a switching center always accessible to the DSO with an isolation function. The switching center is an integral part of the PV inverter type: Fronius IG Plus
Test specification:	
DIN V VDE 0126-1-1: 2006-02	„Automatic switching center between a parallel net generation system and the public low-voltage grid“

The safety concept of the above product tested with the report of 02.07.2007, ref. 2.04.00403.1.0 (arsenal research) corresponds to the safety requirements for the intended purpose valid at the time this certificate was issued.

This document of compliance is valid until:

31.12.2012

Fronius Worldwide - www.fronius.com/addresses

A **Fronius International GmbH**
4600 Wels-Thalheim, Günter-Fronius-Straße 1, Austria
E-Mail: pv@fronius.com
<http://www.fronius.com>

USA **Fronius USA LLC Solar Electronics Division**
10421 Citation Drive, Suite 1100, Brighton, MI 48116
E-Mail: pv-us@fronius.com
<http://www.fronius-usa.com>

Under <http://www.fronius.com/addresses> you will find all addresses of our sales branches and partner firms!